

DMC Co., Ltd.

**Analog Resistive Touch Screen Controller Board
TSC-25/USB Series User's Guide**

Table of Contents

| | |
|--|----|
| 1. PRODUCTS OUTLINE | 2 |
| 1-1. Scope of Application | 2 |
| 1-2. Outline..... | 2 |
| 2. SPECIFICATIONS | 3 |
| 3. PANEL ID SETTING | 4 |
| 4. CONNECTOR TERMINAL ASSIGNMENT | 5 |
| 4-1. Connector terminal assignment..... | 5 |
| 4-2. Mounted connector. | 5 |
| 5. Operation modes and functions | 6 |
| 5-1. Outline..... | 6 |
| 5-2. Initialization mode and idle mode | 7 |
| 5-3. Coordinate data mode..... | 9 |
| 5-4. Calibration data setup mode | 12 |
| 5-5. Calibration data read mode | 17 |
| 5-6. Calibration data mode | 18 |
| 5-7. Panel ID/mode information acquisition | 21 |
| 5-8. Mode list..... | 22 |
| 5-9. Command list | 22 |
| 6. MODIFICATIONS & IMPROVEMENTS | 23 |
| 6-1. Version History | 23 |
| 7. Warranty | 24 |
| 7-1. Warranty Period | 24 |
| 7-2. Warranty Target | 24 |
| 7-3. Warranty Exceptions | 24 |
| 8. PRECAUTIONS FOR USE | 25 |
| 8-1 General cautions | 25 |
| 8-2 Others | 25 |

DIMENSIONAL DRAWING

1. PRODUCTS OUTLINE

1-1. Scope of Application

This specification is to apply to the analog resistive touch screen controller TSC-25/USB series.

| TSC-25/USB series | Outline |
|-------------------|---|
| TSC-25/USB | The connector which DMC specified as the host interface is mounted. |
| TSC-25/USB-E | EEPROM is mounted on TSC-25/USB. |
| TSC-25/USB-B | B type connector of USB standard is mounted. |
| TSC-25/USB-B-E | EEPROM is mounted on TSC-25/USB-B. |

1-2. Outline

TSC-25/USB series are an analog touch screen controller board, which supports A/D conversion for an analog signal of the touch screen to coordinate data in 10 bits resolution and transmits it to PC via USB interface. TSC-25/USB series executes calibrations properly to acquire reliable coordinate data to transmit data to PC even under unstable input condition for the touch screen such as intermittent interruption. TSC-25/USB series provides 6 different types of coordinates output rates from 30pps to 150pps for selection. The point mode can be also selected to output coordinates data only when the touch screen is activated, depending on applications. DMC driver software supports mouse emulation.

2. SPECIFICATIONS

General Specifications

| Description | | Rating | Note |
|-----------------------------|---------------|-------------------------------------|---|
| Operating Temperature Range | | 0°C to +70°C (no condensation) | |
| Storage Temperature Range | | -20°C to +85°C (no condensation) | |
| Power Supply Voltage | | DC 4.4V to 5.25V | Bus power |
| Power Consumption | | 60mA | Vin=5.0V, 150pps when touch screen is activated |
| Transmission System | Transfer Mode | USB V1.1 Low Speed | |
| | | Control Transfer (Command) | |
| | | Interrupt Transfer (Coordinate) | |
| Device Class | | Vendor definition | DMC driver software is required |
| Operating Frequency | | 6MHz | 6MHzfixed |
| Dimension | | 30 x 40 (mm) | |
| Max height of components | | 5.4mm | |
| | | 11mm | With CN3 (USB B type) |
| | | (2mm) | With EEPROM (back side) |

Performance Specifications

| Description | Rating | Note |
|------------------------------------|--|--|
| Coordinate Output Rate (point/sec) | (1) point mode (2) 30p/s (3) 50p/s (4) 80p/s (5) 100p/s (6) 130p/s (7) 150p/s | Default: 150pps with DMC original driver software. |
| Coordinate Resolution | 10bit (1024 x 1024) | The value will be lower in the active area of the touch screen |
| Linearity Error | ±3 LSB | |
| Input Response Time | 10.5ms | Maximum value at 150pps |

3. PANEL ID SETTING

If two touch screens to the same host are connected simultaneously, each TSC-25/USB series to the host needs panel ID setting. Setting is enabled when hardware is reset, where Device Descriptor's iProduct is set to "0" or "1" and this value is identified by the host as panel ID.

This is performed by setting it as ID0 or ID1 by SW1 on a board.

When we ship this product, the panel ID is set as "0". If two touch screens to the same host are connected simultaneously, you have to set ID as "1" about one of TSC-25/USB series.

The condition of SW1 on a board.

(1) Setting ID as "0".

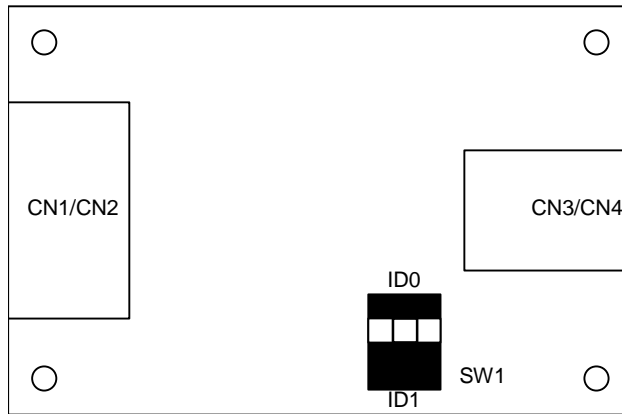

(2) Setting ID as "1".

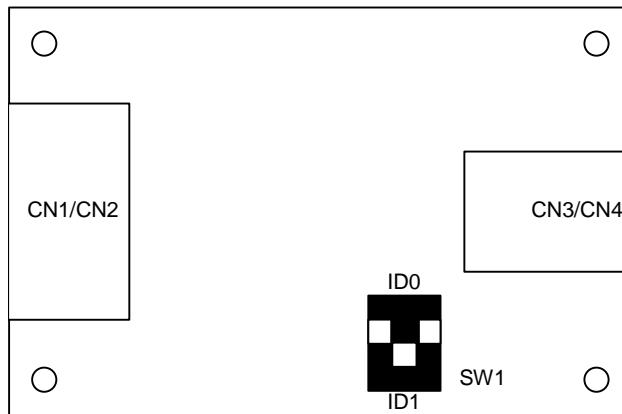

4. CONNECTOR TERMINAL ASSIGNMENT

4-1. Connector terminal assignment.

| CN No. | Pin# | Terminal | Description |
|--------|------|----------|-----------------------|
| CN1 | 1 | UR | Touch screen UR input |
| | 2 | LR | Touch screen LR input |
| | 3 | Sense | Coordinate detection |
| | 4 | UL | Touch screen UL input |
| | 5 | LL | Touch screen LL input |
| CN2 | 1 | UR | Touch screen UR input |
| | 2 | LR | Touch screen LR input |
| | 3 | Sense | Coordinate detection |
| | 4 | UL | Touch screen UL input |
| | 5 | LL | Touch screen LL input |
| CN3 | 1 | Vbus | USB power input |
| | 2 | D- | USB D- |
| | 3 | D+ | USB D+ |
| | 4 | GND | USB GND |
| CN4 | 1 | Vbus | USB power input |
| | 2 | D- | USB D- |
| | 3 | D+ | USB D+ |
| | 4 | GND | USB GND |
| | 5 | FG | USB FG |

4-2. Mounted connector.

| CN No. | Part No. | Manufacturer | Applicable model |
|--------|----------------|---------------------|--------------------|
| CN1 | RE-H052SD-1110 | J.S.T. Mfg Co., Ltd | All models |
| CN3 | UBB-4R-D10T-1 | J.S.T. Mfg Co., Ltd | TSC-25/USB-B(-E)*1 |
| CN4 | S5B-PH-K-S | J.S.T. Mfg Co., Ltd | TSC-25/USB(-E)*1 |

*1 Either CN3 or CN4 is mounted.

5. Operation modes and functions

5-1. Outline

TSC-20/IC enters the Initialization mode immediately after it is turned on or reset. In this mode, no setting is made and each mode shall be set. To transition to the available state, select the coordinate output rate and coordinate output mode and set the operation mode.

§ Initialization mode

By either power supply ON or hardware reset/software reset, the internal initial setting is performed. In the serial scheme, communication with host is available. In USB scheme, device recognition process ends. In this mode, both serial and USB schemes receive a coordinate output rate command and transition to the idle mode.

After hardware reset, it takes 500ms to transition to the initialization mode.

In using the EEPROM, EEPROM data is read in this mode.

§ Idle mode

TSC-20/IC enters this operation waiting mode after the coordinate output rate setting command is received. Transition to each mode takes place in this mode.

§ Coordinate data mode

In this mode, analog data obtained from touch screen is output as coordinate data with 10 bits resolution without any calibration.

This mode starts in the "idle mode" by receiving the coordinate data send start command, and returns to "idle mode" again after receiving the coordinate data send end command. By receiving reset command, it transitions to the "initialization mode".

This mode is used when host driver implements the calibration function, and also when necessary data is obtained in the calibration data setup mode.

§ Calibration data setup mode

In this mode, calibration data used in "calibration data mode" is set. Transition to this mode takes place when the setup mode start command is received in the idle mode. Select an appropriate calibration point among:

- X=2, Y=2 (four point calibration)

- X=3, Y=3 (nine point calibration) and

- X=2, Y=2 (four point calibration) plus one center position (five point calibration)

When this mode ends, calibration data is entered to EEPROM.

§ Calibration data read mode

In this mode, setup data is read out from EEPROM if in using EEPROM, data set in the "calibration data setup mode" is stored to EEPROM. It is used if setting data is to be confirmed. Transition to this mode takes place and calibration data is output to the host if in the idle mode, calibration data read command is received.

§ Calibration data mode

In this mode, individual difference and loss in the touch screen are corrected and coordinate value output is performed. Using calibration data set in the "calibration data setup mode", touch screen input point and indicator's cursor display position can be matched.

In using this mode, the host driver needs no calibration function.

Using "calibration data setup mode" setting value to set the coordinate data maximum value, maximum value can be limited to 10bits or less.

This mode starts when in the idle mode, any "calibration data send start command" is received, and returns to the idle mode when receiving the calibration data send end command. When receiving the reset command, this mode transitions to the initialization mode.

5-2. Initialization mode and idle mode

After the power up or hardware reset, internal initialization setting is performed (in USB mode, setting Descriptor and Address with host) (about 500ms) and the transition to the initialization mode occurs, where waiting for the communication with host. In this mode, if external EEPROM is used, EEPROM data is read. In the initialization mode, use the coordinate output rate setting command to set the interval for sending a coordinate. Where, touch screen connection state and EEPROM data are checked and in either normal or abnormal case, data representing each state is output to the host. Thus, the initialization mode transitions to the idle mode. Transition to each mode occurs from the idle mode. Once coordinate output rate is set with transition to the idle mode, coordinate output rate setting may be available again.

If in either idle mode, coordinate data mode or calibration data mode, reset command is received, transition to the initialization mode occurs. Where, after receiving the reset command, internal processing takes a time, be sure to issue subsequent commands after 6ms or more is elapsed.

§ Mode transition

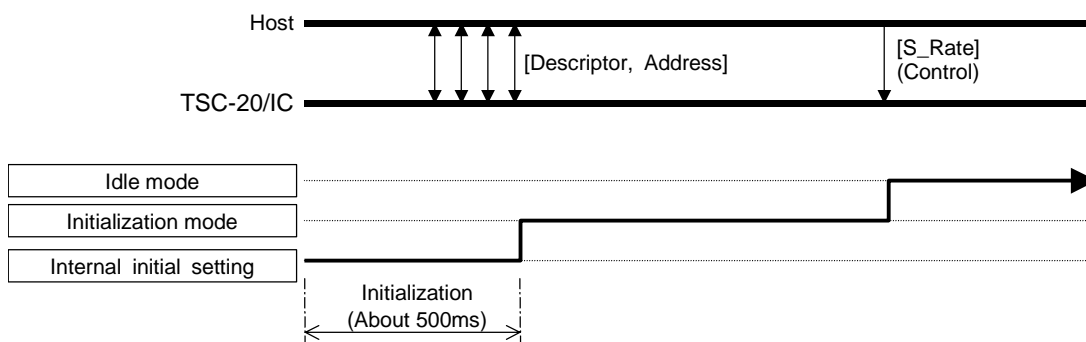

§ USB Device Descriptor

| Offset address | Field name | Bit Width | Contents | Remarks |
|----------------|------------|-----------|----------------------------------|---|
| 8 | idVendor | 2 bytes | 0AFAh | |
| 10 | idProduct | 2 bytes | 03E8h | |
| 15 | iProduct | 1 bytes | 00h:panel ID=0 01h:panel ID=1 | Pin number 3 of TSC-20/IC [SEL1] L: panel ID=0 , H: panel ID=1 |

§ Coordinate output rate setting command (Rate)

| Rate | bmRequest Type | bRequest | wValue | wIndex | wLength | Data |
|-------|----------------|----------|--------|--------|---------|--------------|
| 30 | C0h (IN) | 05h | 0040h | 0000h | 0002h | 0600h/15##h* |
| 50 | C0h (IN) | 05h | 0041h | 0000h | 0002h | 0600h/15##h* |
| 80 | C0h (IN) | 05h | 0042h | 0000h | 0002h | 0600h/15##h* |
| 100 | C0h (IN) | 05h | 0043h | 0000h | 0002h | 0600h/15##h* |
| 130 | C0h (IN) | 05h | 0044h | 0000h | 0002h | 0600h/15##h* |
| 150 | C0h (IN) | 05h | 0045h | 0000h | 0002h | 0600h/15##h* |
| Point | C0h (IN) | 05h | 0050h | 0000h | 0002h | 0600h/15##h* |

#: Differs per error type.

*: Refer to the response command (no EEPROM is used) and response command (EEPROM is used).

§ Response command (no EEPROM is used)

| State | Response command | Byte width | State description |
|----------|------------------|------------|--------------------------------|
| Normal | 0600h | 2 bytes | Touch screen connection normal |
| Abnormal | 1500h | 2 bytes | Touch screen not connected |

§ Response command (EEPROM is used)

| State | Response data | Byte width | State description |
|----------|---------------|------------|---|
| Normal | 0600h | 2 bytes | Touch screen connection, EEPROM data normal |
| Abnormal | 1501h | 2 bytes | EEPROM data empty |
| | 1502h | | EEPROM data abnormal |
| | 1504h | | EEPROM write error |
| | 1508h | | Touch screen not connected |

* If, in the initialization mode, coordinate output rate setting is performed, EEPROM is checked if data is present or not. Thus, error code only refers to EEPROM data empty (detail code: 01h).
 In the idle mode, run the calibration data setup mode. After EEPROM data abnormal or EEPROM write error occurs, set the coordinate output rate, error code is output, indicating EEPROM data abnormal or EEPROM write error. Error flag can be deleted by either hardware reset or software reset.

5-3. Coordinate data mode

Analog data input from analog touch screen is A/D converted for calculating the coordinate data, which is output in this mode.

This mode is used if calibration is made in the host driver. In using the external EEPROM in the calibration data mode, previously performed "calibration data setup mode" needs raw data, which is obtained in this mode.

From the idle mode, this mode starts by receiving either command of coordinate data send start 1 – 3, and returns to the idle mode by receiving the coordinate data send end command. By receiving "reset" command, the mode transition to the initialization mode.

At the touch screen input (when a finger or pen touches on the touch screen), coordinate data, including pen-down ID indicating that touch screen is input, is output to the host with coordinate output rate interval. If the touch screen input ends (when a finger or pen leaves the touch screen), coordinate data including pen-up ID is output (excluding the point mode).

§ Mode transition

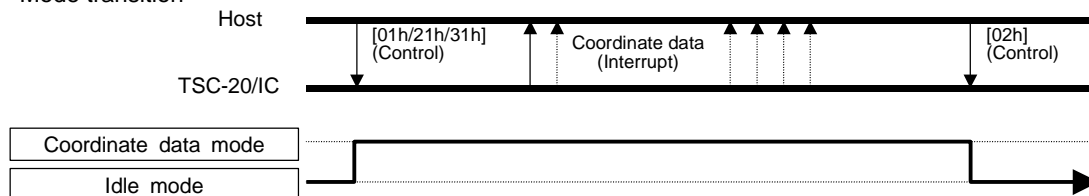

§ Command

| Mode | bmRequest Type | bRequest | wValue | wIndex | wLength | Data |
|------------------------------|----------------|----------|--------|--------|---------|-------|
| Coordinate data send start 1 | 40h (OUT) | 01h | 0000h | 0000h | 0000h | - |
| Coordinate data send start 2 | 40h (OUT) | 21h | 0000h | 0000h | 0000h | - |
| Coordinate data send start 3 | 40h (OUT) | 31h | 0000h | 0000h | 0000h | - |
| Coordinate data send end | C0h (IN) | 02h | 0000h | 0000h | 0002h | 0600h |

§ Each mode function

| Mode | Function |
|------------------------------|---|
| Coordinate data send start 1 | Pen-down: Coordinate data including pen-down ID is output with the coordinate output rate interval. Pen-up: Pen-up ID is output one time. No input: No transition to the power-save mode. |
| Coordinate data send start 2 | Pen-down: Coordinate data including pen-down ID is output with the coordinate output rate interval. Pen-up: Coordinate data including pen-up ID is output with the coordinate output rate interval. No input: No transition to the power-save mode. |
| Coordinate data send start 3 | Pen-down: Coordinate data including pen-down ID is output with the coordinate output rate interval. Pen-up: Pen-up ID is output one time. No input: No transition to the power-save mode. |
| Coordinate data send end | Coordinate data mode ends and transition to the idle mode occurs. |

§ Coordinate format

Pen-down data

| | Meaning | b7 | b6 | b5 | b4 | b3 | b2 | b1 | b0 |
|--------|-------------|-----|-----|----|----|----|----|----|----|
| Byte 0 | Pen Down ID | SW0 | SW1 | 0 | 1 | 0 | 0 | 0 | 1 |
| Byte 1 | X Lower | X7 | X6 | X5 | X4 | X3 | X2 | X1 | X0 |
| Byte 2 | X Upper | 0 | 0 | 0 | 0 | 0 | 0 | X9 | X8 |
| Byte 3 | Y Lower | Y7 | Y6 | Y5 | Y4 | Y3 | Y2 | Y1 | Y0 |
| Byte 4 | Y Upper | 0 | 0 | 0 | 0 | 0 | 0 | Y9 | Y8 |

Pen-up data

| | Meaning | b7 | b6 | b5 | b4 | b3 | b2 | b1 | b0 |
|--------|-----------|-----|-----|----|----|----|----|----|----|
| Byte 0 | Pen Up ID | SW0 | SW1 | 0 | 1 | 0 | 0 | 0 | 0 |
| Byte 1 | X Lower | X7 | X6 | X5 | X4 | X3 | X2 | X1 | X0 |
| Byte 2 | X Upper | 0 | 0 | 0 | 0 | 0 | 0 | X9 | X8 |
| Byte 3 | Y Lower | Y7 | Y6 | Y5 | Y4 | Y3 | Y2 | Y1 | Y0 |
| Byte 4 | Y Upper | 0 | 0 | 0 | 0 | 0 | 0 | Y9 | Y8 |

List of Pen-down ID (pen-down data Byte 0)

| ID | SW0 | SW1 |
|-----|-----|-----|
| 11h | 0 | 0 |
| 51h | 0 | 1 |
| 91h | 1 | 0 |
| D1h | 1 | 1 |

List of pen-up ID (pen-up data Byte 0)

| ID | SW0 | SW1 |
|-----|-----|-----|
| 10h | 0 | 0 |
| 50h | 0 | 1 |
| 90h | 1 | 0 |
| D0h | 1 | 1 |

§ Example of data (transmission starts at receiving [01h] or [31h]) (Where, X = 0374h and Y = 01A9h)

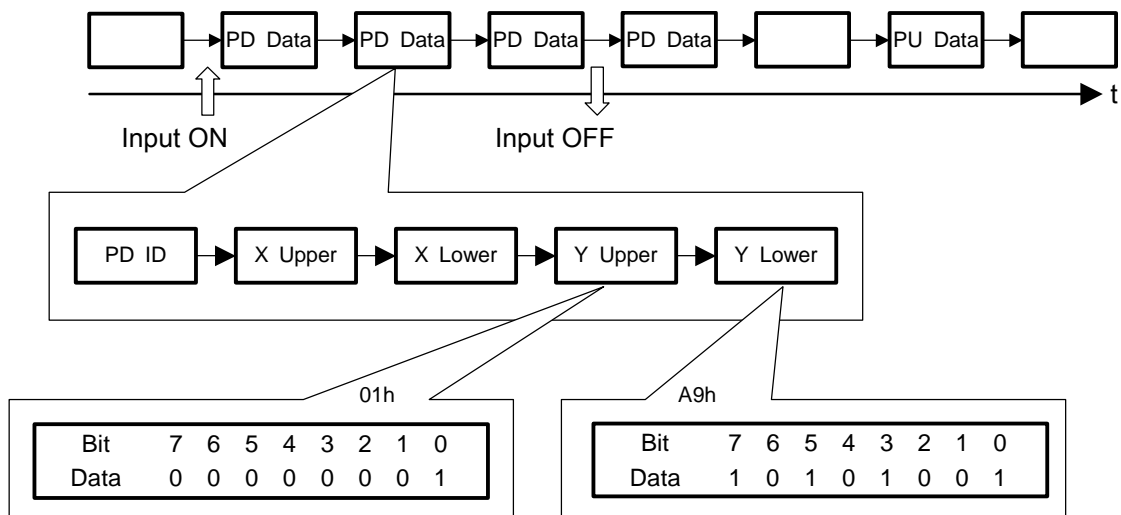

Immediately after Pen-up, if the first sampling is pen-up, immediately preceding pen-down data is output. If second time sampling is pen-up, none is output. If third time sampling is pen-up, pen-up data is output once.

§ Example of data (transmission starts at receiving [21h])

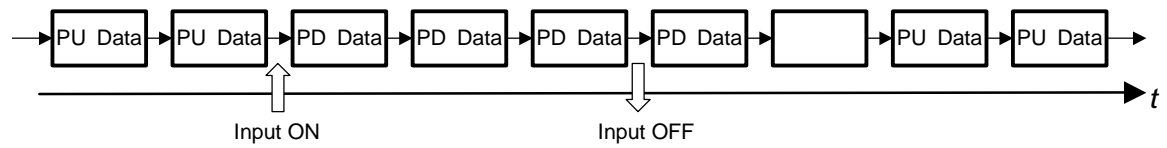

*: Immediately after Pen-up, if the first sampling is pen-up, immediately preceding pen-down data is output. If second time sampling is pen-up, none is output. If third time sampling is pen-up, pen-up data is output. Thereafter, pen-up data is output at the coordinate output rate interval. Coordinate value at pen-up always takes same coordinate value as the last pen-down data. After the coordinate data mode transition until the first pen-down, 0000h is output.

5-4. Calibration data setup mode

On the touch screen, due to offset and rotation caused by shifted pasting on touch screen and elements such as losses from surrounding circuit, touch screen input point and indicator coordinate indication may be unmatched with each other if A/D conversion value is output as coordinate value.

To resolve this, TSC-20/IC defines in advance any point on touch screen as a calibration point, where the calibration point's raw coordinate (A/D conversion value) and calibration coordinate value to be output to the host after calibration, and in the actual operation, from defined coordinate value, corresponding calibration coordinate value of touch screen input point's raw coordinate is calculated and output to the host (calibration data mode).

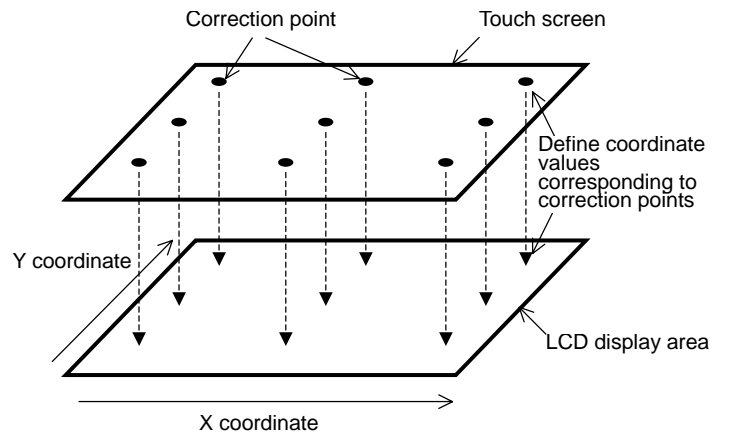

In this mode, data required for calibration is set up. Number of maximum calibration points is nine in total with X = 3 and Y = 3.

For setup in this mode, coordinates of calibration points in the coordinate data mode shall be obtained in advance.

By receiving setup mode start command in the idle mode, the operation transitions to this mode and after setup processing ends, data corresponding to the normal end or abnormal end is output to the host, then the operation returns to the idle mode.

If the external EEPROM is used, this processing writes data to EEPROM.

§ Mode transition

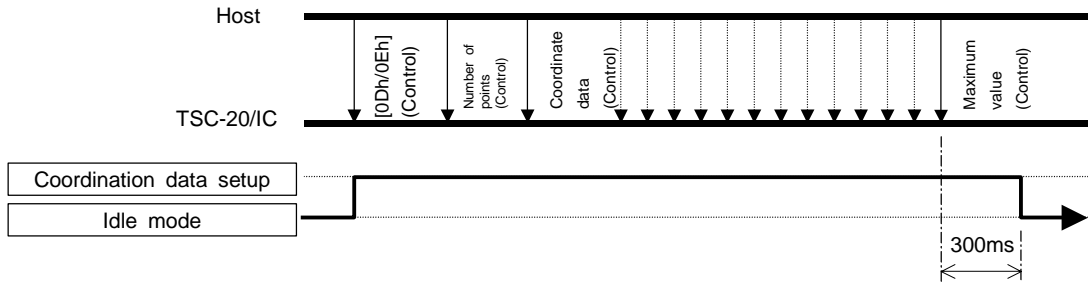

* Within 300ms after the last data (calibration data maximum value) is received and until the transition to the idle mode occurs, no command reception is available.

§ Command

| Mode | bmRequest Type | bRequest | wValue | wIndex | wLength | Data |
|--------------------|----------------|----------|--------|--------|---------|-------------|
| Setup mode start 1 | C0h (IN) | 0Dh | 0000h | 0000h | 0002h | 0600h/150#h |
| Setup mode start 2 | C0h (IN) | 0Eh | 0000h | 0000h | 0002h | 0600h/150#h |

#: Refer to the response command.

§ Function

| Mode | Function |
|--------------------|--|
| Setup mode start 1 | Normal calibration (Specify the number of calibration points in X and Y each) |
| Setup mode start 2 | Five point calibration (four points at touch screen's 4 corners and one point at the center) |

§ Response command

| State | Response command | Bit width | State description |
|----------|-------------------------|-----------|----------------------|
| Normal | 06h + 00h | 2 bytes | EEPROM write normal |
| Abnormal | 15h (NAK) + detail code | 2 bytes | EEPROM data abnormal |
| | bit1=1 (02h) | | |
| | bit2=1 (04h) | | |
| | | | EEPROM write error |

§ Setup procedure

1. Define calibration point and number of calibration points and display a cross mark and arrow on indicator to obtain coordinate values at the calibration point in the coordinate data mode.
2. Transmit command[0Dh/0Eh] to TSC-20/IC (transition to "calibration data setup mode"), and input data according to the calibration data setting format. After all data are input, ACK/NAK is output to the host and the operation automatically transitions to the idle mode.

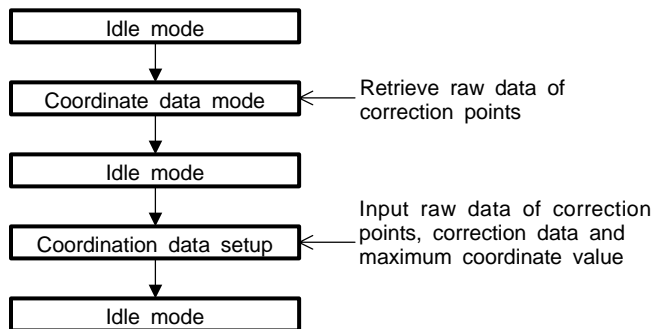

§ Calibration data setting format

Setup mode start 1 (calibration point: nine points (X=3, Y=3), where coordinate maximum value: X=1023 and Y=1023)

Correction point (origin: top left)

| | | |
|-----|-----|-----|
| P00 | P01 | P02 |
| P10 | P11 | P12 |
| P20 | P21 | P22 |

| Off Set | bmRequest Type | bRequest | wValue | wIndex | wLength | Data |
|---------|----------------|----------|-----------|--------|---------|-------------|
| 0 | C0h | 0Dh | 0303h | 0000h | 0002h | 0600h/150#h |
| 1 | C0h | 0Dh | P00 X Raw | 0000h | 0002h | 0600h/150#h |
| 2 | C0h | 0Dh | P00 Y Raw | 0000h | 0002h | 0600h/150#h |
| 3 | C0h | 0Dh | P00 X Cal | 0000h | 0002h | 0600h/150#h |
| 4 | C0h | 0Dh | P00 Y Cal | 0000h | 0002h | 0600h/150#h |
| 5 | C0h | 0Dh | P01 X Raw | 0000h | 0002h | 0600h/150#h |
| 6 | C0h | 0Dh | P01 Y Raw | 0000h | 0002h | 0600h/150#h |
| 7 | C0h | 0Dh | P01 X Cal | 0000h | 0002h | 0600h/150#h |
| 8 | C0h | 0Dh | P01 Y Cal | 0000h | 0002h | 0600h/150#h |
| 9 | C0h | 0Dh | P02 X Raw | 0000h | 0002h | 0600h/150#h |
| 10 | C0h | 0Dh | P02 Y Raw | 0000h | 0002h | 0600h/150#h |
| 11 | C0h | 0Dh | P02 X Cal | 0000h | 0002h | 0600h/150#h |
| 12 | C0h | 0Dh | P02 Y Cal | 0000h | 0002h | 0600h/150#h |
| 13 | C0h | 0Dh | P10 X Raw | 0000h | 0002h | 0600h/150#h |
| 14 | C0h | 0Dh | P10 Y Raw | 0000h | 0002h | 0600h/150#h |
| 15 | C0h | 0Dh | P10 X Cal | 0000h | 0002h | 0600h/150#h |
| 16 | C0h | 0Dh | P10 Y Cal | 0000h | 0002h | 0600h/150#h |
| | | | | | | |
| 33 | C0h | 0Dh | P22 X Raw | 0000h | 0002h | 0600h/150#h |
| 34 | C0h | 0Dh | P22 Y Raw | 0000h | 0002h | 0600h/150#h |
| 35 | C0h | 0Dh | P22 X Cal | 0000h | 0002h | 0600h/150#h |
| 36 | C0h | 0Dh | P22 Y Cal | 0000h | 0002h | 0600h/150#h |
| 37 | C0h | 0Dh | 03FFh | 0000h | 0002h | 0600h/150#h |
| 38 | C0h | 0Dh | 03FFh | 0000h | 0002h | 0600h/150#h |

Error output conditions:

| State | Errors | Output conditions |
|----------|---|--|
| Abnormal | Data abnormal (number of calibration points: 1 or less) | With Off Set 0, 1502h is output and subsequently same data is output |
| | Data abnormal (number of calibration points: 4 or more) | When calibration of 5x5 points ends, 1502 is output. |
| | Data abnormal (coordinate data error) | With Off Set 38 (when all calibration ends), 1502h is output |
| | Write error | With Off Set 38 (when all calibration ends), 1504h is output. |
| Normal | Normal | For all responses, 0600h is output. |

P00 X Raw: P00 X coordinate values in the coordinate data mode.

P22 Y Cal: P22 Calibration coordinate value in Y coordinate.

Off Set 37: Maximum X coordinate value.

Off Set 38: Maximum Y coordinate value.

Setup mode start 1 (calibration point: four points (X=2, Y=2), where coordinate maximum value X=511, Y=511)

Correction point (origin: top left)

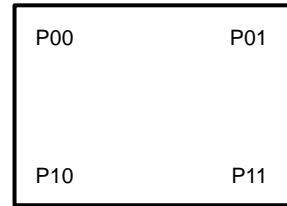

| Off Set | bmRequest Type | bRequest | wValue | wIndex | wLength | Data |
|---------|----------------|----------|-----------|--------|---------|-------------|
| 0 | C0h | 0Dh | 0202h | 0000h | 0002h | 0600h/1500h |
| 1 | C0h | 0Dh | P00 X Raw | 0000h | 0002h | 0600h/1500h |
| 2 | C0h | 0Dh | P00 Y Raw | 0000h | 0002h | 0600h/1500h |
| 3 | C0h | 0Dh | P00 X Cal | 0000h | 0002h | 0600h/1500h |
| 4 | C0h | 0Dh | P00 Y Cal | 0000h | 0002h | 0600h/1500h |
| 5 | C0h | 0Dh | P01 X Raw | 0000h | 0002h | 0600h/1500h |
| 6 | C0h | 0Dh | P01 Y Raw | 0000h | 0002h | 0600h/1500h |
| 7 | C0h | 0Dh | P01 X Cal | 0000h | 0002h | 0600h/1500h |
| 8 | C0h | 0Dh | P01 Y Cal | 0000h | 0002h | 0600h/1500h |
| 9 | C0h | 0Dh | P10 X Raw | 0000h | 0002h | 0600h/1500h |
| 10 | C0h | 0Dh | P10 Y Raw | 0000h | 0002h | 0600h/1500h |
| 11 | C0h | 0Dh | P10 X Cal | 0000h | 0002h | 0600h/1500h |
| 12 | C0h | 0Dh | P10 Y Cal | 0000h | 0002h | 0600h/1500h |
| 13 | C0h | 0Dh | P11 X Raw | 0000h | 0002h | 0600h/1500h |
| 14 | C0h | 0Dh | P11 Y Raw | 0000h | 0002h | 0600h/1500h |
| 15 | C0h | 0Dh | P11 X Cal | 0000h | 0002h | 0600h/1500h |
| 16 | C0h | 0Dh | P11 Y Cal | 0000h | 0002h | 0600h/1500h |
| 17 | C0h | 0Dh | 01FFh | 0000h | 0002h | 0600h/1500h |
| 18 | C0h | 0Dh | 01FFh | 0000h | 0002h | 0600h/1500h |

Setup mode start 2 (where coordinate maximum value X=1023 and Y=1023)

* Stored in EEPROM by conversion into 3x3 format.

Correction point (origin: top left)

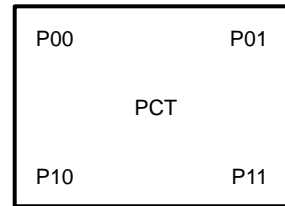

| Off Set | bmRequest Type | bRequest | wValue | wIndex | wLength | Data |
|---------|----------------|----------|-----------|--------|---------|-------------|
| 1 | C0h | 0Eh | P00 X Raw | 0000h | 0002h | 0600h/1500h |
| 2 | C0h | 0Eh | P00 Y Raw | 0000h | 0002h | 0600h/1500h |
| 3 | C0h | 0Eh | P00 X Cal | 0000h | 0002h | 0600h/1500h |
| 4 | C0h | 0Eh | P00 Y Cal | 0000h | 0002h | 0600h/1500h |
| 5 | C0h | 0Eh | P01 X Raw | 0000h | 0002h | 0600h/1500h |
| 6 | C0h | 0Eh | P01 Y Raw | 0000h | 0002h | 0600h/1500h |
| 7 | C0h | 0Eh | P01 X Cal | 0000h | 0002h | 0600h/1500h |
| 8 | C0h | 0Eh | P01 Y Cal | 0000h | 0002h | 0600h/1500h |
| 9 | C0h | 0Eh | P10 X Raw | 0000h | 0002h | 0600h/1500h |
| 10 | C0h | 0Eh | P10 Y Raw | 0000h | 0002h | 0600h/1500h |
| 11 | C0h | 0Eh | P10 X Cal | 0000h | 0002h | 0600h/1500h |
| 12 | C0h | 0Eh | P10 Y Cal | 0000h | 0002h | 0600h/1500h |
| 13 | C0h | 0Eh | P11 X Raw | 0000h | 0002h | 0600h/1500h |
| 14 | C0h | 0Eh | P11 Y Raw | 0000h | 0002h | 0600h/1500h |
| 15 | C0h | 0Eh | P11 X Cal | 0000h | 0002h | 0600h/1500h |
| 16 | C0h | 0Eh | P11 Y Cal | 0000h | 0002h | 0600h/1500h |
| 17 | C0h | 0Eh | PCT X Raw | 0000h | 0002h | 0600h/1500h |
| 18 | C0h | 0Eh | PCT Y Raw | 0000h | 0002h | 0600h/1500h |
| 19 | C0h | 0Eh | PCT X Cal | 0000h | 0002h | 0600h/1500h |
| 20 | C0h | 0Eh | PCT Y Cal | 0000h | 0002h | 0600h/1500h |
| 21 | C0h | 0Eh | 03FFh | 0000h | 0002h | 0600h/1500h |
| 22 | C0h | 0Eh | 03FFh | 0000h | 0002h | 0600h/1500h |

§ Handling of outside the coordinate range

If a portion only of the touch screen is to be operated, some calibration may cause the touch screen input points even inside the input area to be located outside the maximum coordinate point (or minimum coordinate point). Where, touch screen input is not disabled and the following data is transmitted.

Minimum coordinate value (X = 00 00, Y= 00 00)

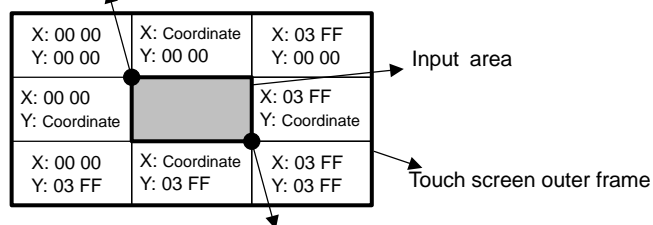

Maximum coordinate value (X = 03 FF, Y= 03 FF)

5-5. Calibration data read mode

In this mode, data set in the calibration data setup mode is read from EEPROM, used to check the parameter setting.

This mode is executed from idle mode to transmit the stored calibration data, then the operation automatically transitions to idle mode. If no calibration data is stored in EEPROM, none is output.

Note) In this mode, number of calibration points is treated with 25 point (X=5, Y=5) format, since FIT-10/IC, a touch screen controller IC, supports the maximum 25 point calibration function and protocol compatibility in the serial mode shall be kept with FIT-10/IC. Coordinate data of calibration points not supported by TSC-20/IC are all output with 0000h.

§ Mode transition

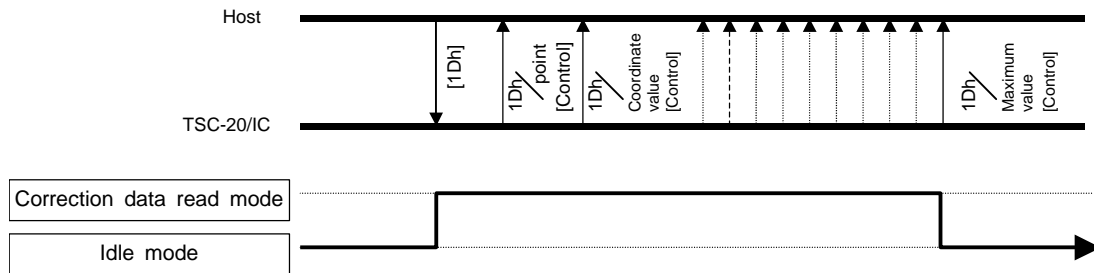

§ Calibration data send format

In the idle mode, if 1Dh is received, calibration data is output to the host as response data to IN token with the following format.

In the calibration data setup mode, if setup mode start 2 (bRequest= 0Eh) is used, data is converted to nine point calibration (X=3, Y=3) for setup mode start 1 (0Dh) then stored, thus if output to the host, it uses nine point calibration format.

Correction points (5×5)

| | | | | |
|-----|-----|-----|-----|-----|
| P00 | P01 | P02 | P03 | P04 |
| P10 | P11 | P12 | P13 | P14 |
| P20 | P21 | P22 | P23 | P24 |
| P30 | P31 | P32 | P33 | P34 |
| P40 | P41 | P42 | P43 | P44 |

| Off Set | bmRequest Type | bRequest | wValue | wIndex | wLength | Data |
|---------|----------------|----------|--------|--------|---------|-----------|
| 0 | C0h (IN) | 1Dh | 0000h | 0000h | 0002h | X/Y Point |
| 1 | C0h (IN) | 1Dh | 0000h | 0000h | 0008h | P00 X/Y |
| 2 | C0h (IN) | 1Dh | 0000h | 0000h | 0008h | P01 X/Y |
| 3 | C0h (IN) | 1Dh | 0000h | 0000h | 0008h | P02 X/Y |
| 4 | C0h (IN) | 1Dh | 0000h | 0000h | 0008h | P03 X/Y |
| 5 | C0h (IN) | 1Dh | 0000h | 0000h | 0008h | P04 X/Y |
| 6 | C0h (IN) | 1Dh | 0000h | 0000h | 0008h | P10 X/Y |
| ⋮ | | | | | | |
| 21 | C0h (IN) | 1Dh | 0000h | 0000h | 0008h | P40 X/Y |
| 22 | C0h (IN) | 1Dh | 0000h | 0000h | 0008h | P41 X/Y |
| 23 | C0h (IN) | 1Dh | 0000h | 0000h | 0008h | P42 X/Y |
| 24 | C0h (IN) | 1Dh | 0000h | 0000h | 0008h | P43 X/Y |
| 25 | C0h (IN) | 1Dh | 0000h | 0000h | 0008h | P44 X/Y |
| 26 | C0h (IN) | 1Dh | 0000h | 0000h | 0004h | X/Y Max |

5-6. Calibration data mode

In this mode, based on calibration value obtained from the calibration data setup mode, coordinate value is corrected and output. In this mode, maximum output coordinate value can be limited.

From the idle mode, this mode starts by receiving either command of coordinate data send start 1 – 3, and returns to the idle mode by receiving the calibration data send end command. By receiving “reset” command, the mode transition to the initialization mode.

At the touch screen input (when a finger or pen touches on the touch screen), coordinate data, including pen-down ID indicating that touch screen is input, is output to the host with coordinate output rate interval. If the touch screen input ends (when a finger or pen leaves the touch screen), in the serial mode, pen-up ID of 1byte is output, or in the USB mode, coordinate data including pen-up ID is output (excluding the point mode).

§ Mode transition

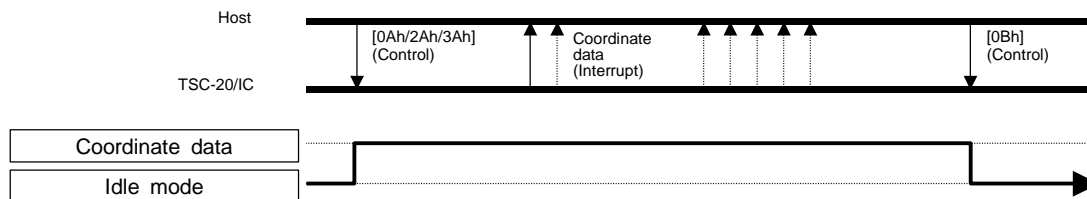

§ Command

| Mode | bmRequest Type | bRequest | wValue | wIndex | wLength | Data |
|-------------------------------|----------------|----------|--------|--------|---------|-------|
| Calibration data send start 1 | 40h (OUT) | 0Ah | 0000h | 0000h | 0000h | - |
| Calibration data send start 2 | 40h (OUT) | 2Ah | 0000h | 0000h | 0000h | - |
| Calibration data send start 3 | 40h (OUT) | 3Ah | 0000h | 0000h | 0000h | - |
| Calibration data send end | C0h (IN) | 0Bh | 0000h | 0000h | 0002h | 0600h |

§ Mode function

| Mode | Function |
|-------------------------------|---|
| Calibration data send start 1 | Pen-down: Coordinate data including pen-down ID is output with the coordinate output rate interval. Pen-up: Pen-up ID is output one time. No input: No transition to the power-save mode. |
| Calibration data send start 2 | Pen-down: Coordinate data including pen-down ID is output with the coordinate output rate interval. Pen-up: Coordinate data including pen-up ID is output with the coordinate output rate interval. No input: No transition to the power-save mode. |
| Calibration data send start 3 | Pen-down: Coordinate data including pen-down ID is output with the coordinate output rate interval. Pen-up: Pen-up ID is output one time. No input: No transition to the power-save mode. |
| Calibration data send end | Coordinate data mode ends and transition to the idle mode occurs. |

§ Data description

Pen-down data

| | Meaning | b7 | b6 | b5 | b4 | b3 | b2 | b1 | b0 |
|--------|-------------|-----|-----|----|----|----|----|----|----|
| Byte 0 | Pen Down ID | SW0 | SW1 | 0 | 1 | 0 | 0 | 0 | 1 |
| Byte 1 | X Lower | X7 | X6 | X5 | X4 | X3 | X2 | X1 | X0 |
| Byte 2 | X Upper | 0 | 0 | 0 | 0 | 0 | 0 | X9 | X8 |
| Byte 3 | Y Lower | Y7 | Y6 | Y5 | Y4 | Y3 | Y2 | Y1 | Y0 |
| Byte 4 | Y Upper | 0 | 0 | 0 | 0 | 0 | 0 | Y9 | Y8 |

Pen-up data

| | Meaning | b7 | b6 | b5 | b4 | b3 | b2 | b1 | b0 |
|--------|-----------|-----|-----|----|----|----|----|----|----|
| Byte 0 | Pen Up ID | SW0 | SW1 | 0 | 1 | 0 | 0 | 0 | 0 |
| Byte 1 | X Lower | X7 | X6 | X5 | X4 | X3 | X2 | X1 | X0 |
| Byte 2 | X Upper | 0 | 0 | 0 | 0 | 0 | 0 | X9 | X8 |
| Byte 3 | Y Lower | Y7 | Y6 | Y5 | Y4 | Y3 | Y2 | Y1 | Y0 |
| Byte 4 | Y Upper | 0 | 0 | 0 | 0 | 0 | 0 | Y9 | Y8 |

List of pen-down ID (pen-down data Byte 0)

| ID | SW0 | SW1 |
|-----|-----|-----|
| 11h | 0 | 0 |
| 51h | 0 | 1 |
| 91h | 1 | 0 |
| D1h | 1 | 1 |

List of pen-up ID (pen-up data Byte 0)

| ID | SW0 | SW1 |
|-----|-----|-----|
| 10h | 0 | 0 |
| 50h | 0 | 1 |
| 90h | 1 | 0 |
| D0h | 1 | 1 |

§ Example of data ([transmission starts by receiving 0Ah] or [3Ah]) (Where, X = 0374h and Y = 01A9h)

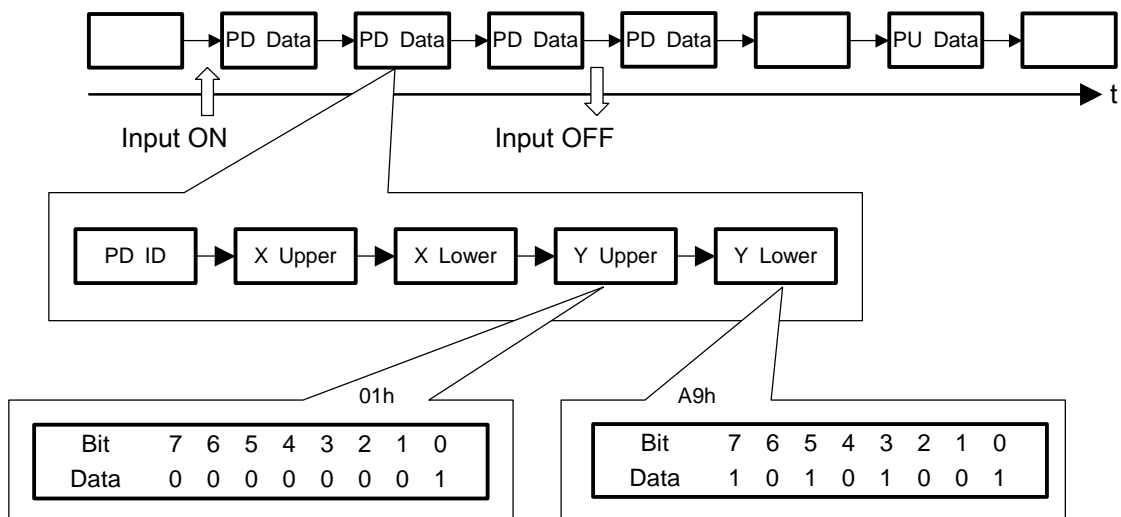

Immediately after Pen-up, if the first sampling is pen-up, immediately preceding pen-down data is output. If second time sampling is pen-up, none is output. If third time sampling is pen-up, pen-up data is output once.

§ Example of Data (transmission starts by receiving [2Ah])

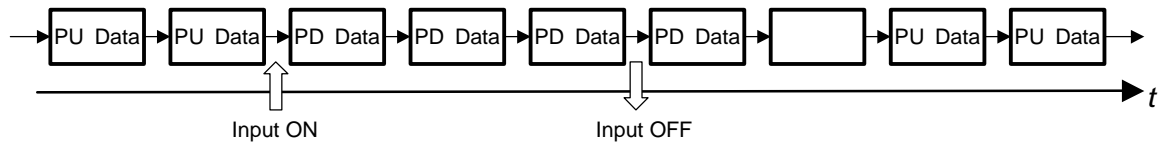

*: Immediately after Pen-up, if the first sampling is pen-up, immediately preceding pen-down data is output. If second time sampling is pen-up, none is output. If third time sampling is pen-up, pen-up data is output. Thereafter, pen-up data is output at the coordinate output rate interval. Coordinate value at pen-up always takes same coordinate value as the last pen-down data. After the coordinate data mode transition until the first pen-down, 0000h is output.

5-7. Panel ID/mode information acquisition

This function is used to obtain panel ID in the USB mode, current transition mode, and used/unused status information of SW0, SW1 and EEPROM. It is used to know the current operation status.

This function is available in initialization mode, idle mode, coordinate data mode and calibration data mode.

Panel ID is enabled by releasing hardware reset. Thus, if, after hardware reset, pin information was changed, restart the power or reset hardware to enable the setting.

Mode information always outputs the last command. Therefore, be sure that even in the idle mode, output data differs per last command.

This function is used to check panel ID, current mode used/unused status of SW0, SW1 and EEPROM.

§ Command

| bmRequest Type | bRequest | wValue | wIndex | wLength | Data | Command enabled mode |
|----------------|----------|--------|--------|---------|--------|--|
| C0h (IN) | 15h | 0000h | 0000h | 0002h | Value* | Initialization mode Idle mode Coordinate (calibration) data mode |

*: Refer to detailed output data description.

§ Output data description

Data content: Byte 1 (Upper bits: b15 - b8) includes the transition mode information, and byte 2 (lower bits: b7 - b0) outputs the setting information. In USB mode, b4 is fixed to "1".

| Bit | Bit information | |
|---|--|--|
| b0 | Fixed to "0" | |
| b1 | Panel ID (pin number 3) | "1" = PID 1 "0" = PID 0 |
| b2 | SW1 (pin number 28) | "1" = SW ON "0" = SW OFF |
| b3 | SW0 (pin number 29) | "1" = SW ON "0" = SW OFF |
| b4 | USB/RS (pin number 25) | "1" = USB "0" = RS |
| b5 | Fixed to "0" | |
| b6 | Fixed to "1" | |
| b7 | SEL4/EEP-CS (pin number 16) | "1" = EEPROM Unused "0" = EEPROM Used |
| b8-15 | Transition mode information | |
| | 00h: initialization mode | |
| | 05h: idle mode (immediately preceding command sets the coordinate output rate) | |
| | 01h: coordinate data mode start 1 | |
| | 21h: coordinate data mode start 2 | |
| | 31h: coordinate data mode start 3 | |
| | 02h: idle mode (immediately preceding command is 02h) | |
| | 0Ah: calibration data mode start 1 | |
| | 2Ah: calibration data mode start 2 | |
| | 3Ah: calibration data mode start 3 | |
| 0Bh: idle mode (immediately preceding command is 0Bh) | | |

5-8. Mode list

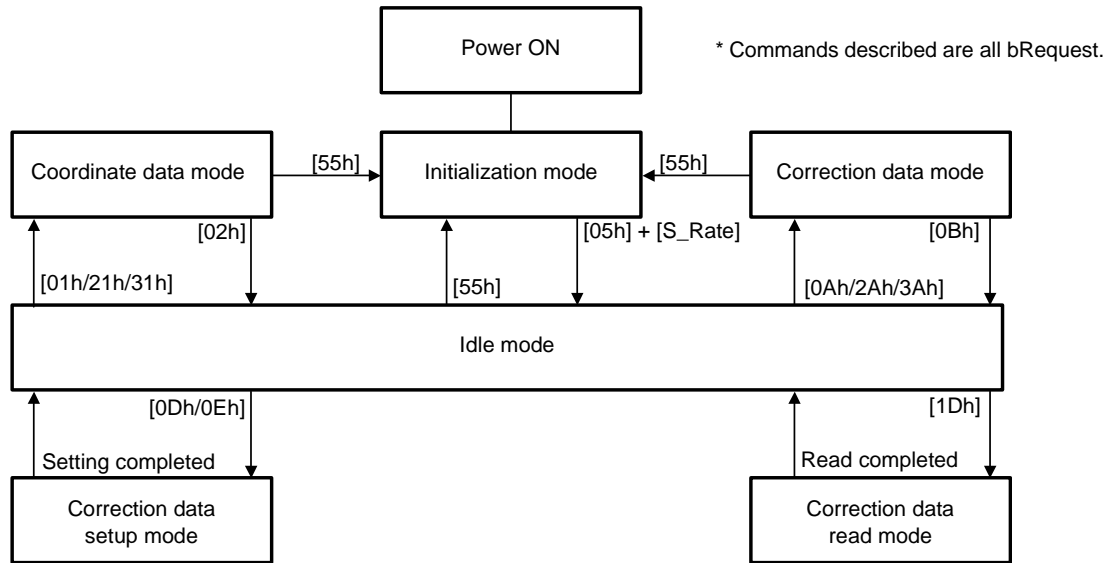

5-9. Command list

| bmRequest Type | bRequest | wValue | wIndex | wLength | DATA | Command name |
|----------------|----------|--------|--------|---------------------------|--------|---|
| 40h (OUT) | 00h | 0000h | 0000h | 0000h | Unused | Null |
| C0h (IN) | 05h | Value | 0000h | 0002h | Used | Coordinate output rate setting |
| 40h (OUT) | 01h | 0000h | 0000h | 0000h | Unused | Coordinate data send start 1 |
| 40h (OUT) | 21h | 0000h | 0000h | 0000h | Unused | Coordinate data send start 2 |
| 40h (OUT) | 31h | 0000h | 0000h | 0000h | Unused | Coordinate data send start 3 |
| C0h (IN) | 02h | 0000h | 0000h | 0002h | Used | Coordinate data send end |
| 40h (OUT) | 0Ah | 0000h | 0000h | 0000h | Unused | Calibration data send start 1 |
| 40h (OUT) | 2Ah | 0000h | 0000h | 0000h | Unused | Calibration data send start 2 |
| 40h (OUT) | 3Ah | 0000h | 0000h | 0000h | Unused | Calibration data send start 3 |
| C0h (IN) | 0Bh | 0000h | 0000h | 0002h | Used | Calibration data send end |
| C0h (IN) | 0Dh | Value | 0000h | 0002h | Used | Calibration data setup (1) |
| C0h (IN) | 0Eh | Value | 0000h | 0002h | Used | Calibration data setup (2) |
| C0h (IN) | 1Dh | 0000h | 0000h | 0002h/ 0004h/ 0008h | Used | Calibration data read wLength: 206bytes in total |
| C0h (IN) | 55h | 0000h | 0000h | 0002h | Used | Reset |
| C0h (IN) | 15h | 0000h | 0000h | 0002h | Used | Panel ID/ mode information retrieval |

§ Wait after issuing command

After issuing the following commands, wait as specified before issuing the next command.

| Command name | USB command (bRequest) | Wait time |
|----------------------------|------------------------|--|
| Reset | 55h | 6ms |
| Calibration data setup (1) | 0Dh | 300ms after issuing last data |
| Calibration data setup (2) | 0Eh | 300ms after issuing last data |
| Calibration data read | 1Dh | 0ms after reading last data (no wait required) |

6. MODIFICATIONS & IMPROVEMENTS

6-1. Version History

TSC-25/USB series

Rev. 1.0 (August 9, 2005) First Edition

Rev.1.1 (November 2, 2005) Item 7 (Warranty) is added.

Rev.1.2 (July 20, 2006) Item 5-7. Panel ID/mode information acquisition
§ Output data description: b6 was changed to [Fixed to "1"].

7. Warranty

7-1. Warranty Period

- § The warranty period is limited to 1 year from the date of shipping. The warranty for the initial deflection such as appearance deflection is limited to 1 month.
- § Any defected parts under proper use will be examined by the supplier and replaced by the new parts if the deflection is considered to be caused by the supplier.
- § The replacement is subject to be included in the next lot.

7-2. Warranty Target

- § The warranty only covers the product itself and does not cover any damage to others caused by using this product. Onsite repair or replacement is not supported.
- § We will do our best for delivery problem and product defections, but the warranty for the production line is not covered.

7-3. Warranty Exceptions

Following conditions are not covered with the warranty and subject to charge.

- § Any malfunctions and damages during transportation and transfer by the user.
- § Any malfunctions and damages caused by a natural disaster or a fire.
- § Any malfunctions and damages caused by static electricity
- § Any malfunctions and damages caused by the failure of the associated equipment.
- § If the product is remodeled, disassembled or repaired by the user.
- § If the product is glued onto the equipment and uninstalled.
- § Any malfunctions and damages caused by an improper usage and handling against the specifications and notes.

8. PRECAUTIONS FOR USE

8-1 General cautions

- § Do not place any conductive materials like metals closer to TSC-25/USB series.
- § Do not touch any metal part of TSC-25/USB series as it may be damaged by static electricity. Use antistatic table in case of touching it by hand.
- § Keep TSC-25/USB series in a carton box without any other abnormal loading pressure under storage temperature and humidity environment.
- § TSC-25/USB series should not be used or stored under environments as below:
 - Wet (or may wet) environments.
 - Condensation (or likely to occur condensation)
 - Organic solvent or acidic substance environments.
- § Re-modeling or disassemble is your own risk.

8-2 Others

- § This specification is subject to change for improvements without prior notice.
- § DMC is not responsible for any damage or loss caused by use of TSC-25/USB series.
- § TSC-25/USB series are designed for general purpose (such as office use, industrial machines, communication equipments and home appliances). It should NOT be used for the application where any irregular operation may harm or damage to human or any special purposes which require higher reliability such as medical, aerospace and nuclear equipments).
- § Please pay careful attention to safety guard when designing your products to avoid accidental death, fire or any social damages.

TSC-25/USB Series User's Guide

Rev. 1.2, July 20, 2006

©2005-2006 DMC Co., Ltd.

Reprint of this user guide may be permitted upon request but not allowed to revise this user guide.



DMC Co., Ltd.

<http://www.dmccoltd.com>

9th floor, Kanda Sento Building, 1-2-4 Yushima, Bunkyo-Ku, Tokyo 113-0034, Japan

Phone: +81-3-5209-7131 (Japanese), 7135 (English) Fax: +81-3-5209-7130

