

**DMC Co., Ltd.**

**Analog Resistive Touch Screen Controller  
TSC-40/IC product specification**

## Table of Contents

<b>1. PRODUCTS OUTLINE .....</b>	<b>2</b>
1-1. Scope of Application .....	2
1-2. Outline .....	2
1-3. Features .....	2
1-4. General specification .....	3
<b>2. Pin layout and representation .....</b>	<b>4</b>
<b>3. Pin functions .....</b>	<b>5</b>
<b>4. Initial setting .....</b>	<b>7</b>
4-1. EEPROM setting .....	7
4-2. Touch screen mode setting .....	7
4-3. Power supply voltage setting .....	7
<b>5. Data sheet .....</b>	<b>8</b>
5-1. Absolute maximum rating .....	8
5-2. Recommended operational conditions .....	9
5-3. Timing requirement .....	10
5-4. DC standards .....	11
<b>6. Packaging Specification .....</b>	<b>12</b>
6-1. Outline .....	12
6-2. Notes on storage/handling .....	12
6-3. Basic packaging .....	12
6-4. Small group packaging .....	13
6-5. Tray specification .....	14
6-6. Product name label specification .....	14
<b>7. Storage Specification .....</b>	<b>15</b>
7-1. Storage Conditions .....	15
7-2. Baking .....	15
<b>8. Implementation Temperature Specification .....</b>	<b>16</b>
<b>9. Terminal Pin Specification .....</b>	<b>17</b>
<b>10. Cleaning .....</b>	<b>17</b>
<b>11. Changes and improvements .....</b>	<b>18</b>
11-1. Version history .....	18
<b>12. Warranty .....</b>	<b>19</b>
12-1. Warranty Period .....	19
12-2. Warranty Target .....	19
12-3. Warranty Exceptions .....	19
<b>13. Notes on use .....</b>	<b>20</b>
13-1. Overall handling .....	20
13-2. Others .....	20

## Dimensional Drawing

## Circuit Diagram

## 1. PRODUCTS OUTLINE

### 1-1. Scope of Application

This specification applies to the TSC-40/IC.

### 1-2. Outline

TSC-40/IC is an analog touch screen control IC that performs A/D conversion on analog signal for the 4-wire and 5-wire resistive analog touch screen, and transmits coordination data with 10bit resolution to the host in a 9600bps serial (asynchronous).

The serial communication enables a connection with PC's serial port via RS-232C I/F circuit or TTL level.

At the coordinate detection, internal filtering process provides a stabilized coordinate value. By using the correction function, in addition to the losses that occur in the circuit, display deflection between touch screen input point that occur in each element and indicator cursor can be corrected to adjust the display position.

### 1-3. Features

- § Two coordinate output modes are provided and selected per application: "Coordinate data mode" where coordinate information is sent with 10bit resolution as it is, and "correction data mode" where read coordinate is converted to the indicator's display coordinate and sent.
- § "Correction data mode" is available after EEPROM is externally attached. It enables to set up to nine correction points. Coordinate data can be corrected with the base of correction points. Using this function allows the host driver to make the implementation of correction function unnecessary. In addition, by placing correction points at the touch screen center and center points of four edges of touch screen, resistance value deviation of transparent electrode film can be corrected.
- § Two external switch functions are always available in the coordinate (correction) data mode. Two pieces of external switch information are, at the transmission of coordinate data, included in the coordinate data as pen-down/pen-up information. Since in the pen-up mode, pen-up data can be always output to the host, this switch is available as a function switch.
- § At the touch screen input, buzzer and LED outputs are available. Input confirmation via display and sound is available.
- § When no touch screen input is performed, the state moves to "power-save mode" so that such application can be supported that requests a low power consumption.
- § Seven types of coordinate output rates are provided and either can be selected per application among seven types: six types from 30 to 150p/s plus one type, a point mode that outputs the coordinate only one time when pen-down is performed.

## 1-4. General specification

Item	Rating	Notes
Power supply voltage	DC 3.3V to 5.5V	
Power consumption	29.5mW (standard)	
Operating Temp	-20 °C to +85 °C (No dew condensation)	
Temperature range at storing	-40 °C to +125 °C (No dew condensation)	
Communication scheme	Communication scheme	Asynchronous, serial
	Communication rate	9600bps
	Data length	8bits
	Stop bit	1bit
	Parity	None
Operation frequency	6MHz	Fixed to 6MHz
Coordinate output rate (point / second)	(1) Point mode (2) 30p/s      (3) 50p/s (4) 80p/s      (5) 100p/s (6) 130p/s     (7) 150p/s	Point Mode: Only when touch screen is input, pen-down ID is sent once. After input ends, no pen-up ID is sent.
Linearity error	±3 LSB	
Input response time	10ms (TYP)	150p/s, For coordinate data mode.
Coordinate resolution	10bit (1024×1024)	In the correction data function, resolution follows the setting value
Dimension (mm)	9×9×1.7	

2. Pin layout and representation

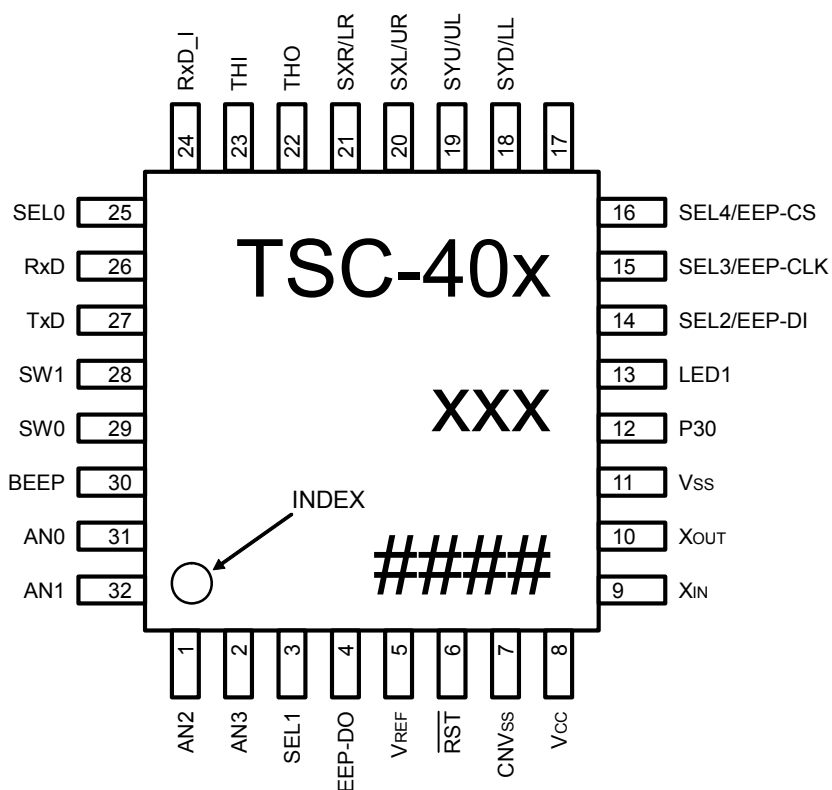

Marking specification

TSC-40x    Product number    x: version number  
 xxx        ROM number  
 #####    Lot number

## 3. Pin functions

Pin number	Pin name	I/O	Functional description
1	AN2	I/O	Touch screen XL/UR input pin.
2	AN3	I/O	Touch screen XR/LL input pin.
3	SEL1	I	Transition select pin. H = Auto transition*1 after reset. L = transition by command.
4	EEP-DO	I	EEPROM DO input pin; At using no EEPROM, Vcc or GND is connected.
5	VREF	I	A/D converter reference voltage input pin; Vcc is connected.
6	$\overline{\text{RST}}$	I	Reset input pin (active L).
7	CNVss	I	Operation mode control pin; Vss is connected.
8	Vcc	I	Power supply input pin; Vcc is connected.
9	XIN	I	Clock input pin; When using external clock, clock is input to this pin.
10	XOUT	O	Clock output pin; When using external clock, this pin is opened.
11	Vss	I	Power supply input pin (GND); GND is connected.
12	P30	O	Opened*2.
13	LED1	O	LED output pin; ON = Lo, OFF = Hi.
14*3	SEL2/EEP-DI	I/O	EEPROM DI signal output pin; When using EEPROM, EEPROM DI is connected. Whether or not EEPROM is used, connect with GND via resistance.
15*3	SEL3/EEP-CLK	I/O	EEPROM SK signal output pin; When using EEPROM, EEPROM SK is connected. Touch screen mode setting pin. (L=4-wire, H=5-wire) Whether or not EEPROM is used, connect with Vcc or GND via resistance.
16*3	SEL4/EEP-CS	I/O	EEPROM setting pin shared with EEPROM CS signal output pin. EEPROM is set via resistance and Vcc or GND is connected. (L = Used, H = Not used). When using EEPROM, EEPROM CS is connected.
17		O	Unused pin; Opened.
18	SYD/LL	O	Touch screen LL control pin.
19	SYU/UL	O	Touch screen UL control pin.
20	SXL/UR	O	Touch screen UR control pin.
21	SXR/LR	O	Touch screen LR control pin.
22	THO	O	Pen down detection pin.
23	THI	I	In power-save mode, start signal input pin by pen down.
24	RxD_I	I	In power-save mode, start signal input pin by command reception. Only used serial mode, RxD is connected.
25	SEL0	I	If power supply voltage is 4.0 to 5.5V, GND is connected. If power supply voltage is 3.3 to 4.0V, Vcc is connected.
26	RxD	I/O	Data receive pin.
27	TxD	I/O	Data send pin.
28	SW1	I	SW1 input pin *4; H = ON = 1, L = OFF = 0.
29	SW0	I	SW0 input pin *4; H = ON = 1, L = OFF = 0.
30	BEEP	O	BEEP output pin; Hi output; Output frequency =2.5kHz, Output time =50ms.
31	AN0	I	Touch screen YD/LL input pin.
32	AN1	I	Touch screen YU/Sense input pin.

- \*1: Auto transition = Mode changes by a command are not performed. It becomes a "Coordinate Data Mode (150pps)" immediately after reset.
- \*2: Always open. If connected with VCC, VSS, or other circuit, an error operation may occur.
- \*3: About pin number 14, 15 and 16, immediately after a power supply injection, it works as an input terminal and becomes an output terminal after that. Do not open these terminals.
- \*4: If neither SW0 nor SW1 function is used, connect 28 and 29 pins to GND directly.

## 4. Initial setting

### 4-1. EEPROM setting

Depending on that calibration is performed in either TSC-40/IC or host, you can select whether EEPROM is used or not to store the correction data. EEPROM selection can be set via pin number 16, where hardware reset release enables the setting.

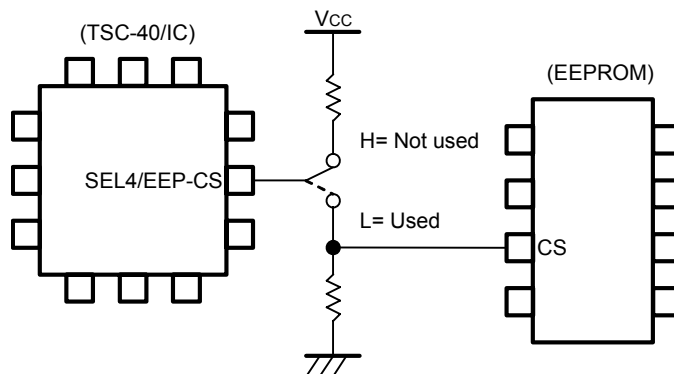

### 4-2. Touch screen mode setting

Touch screen mode setting for 4-wire/5-wire is performed by setting pin number 15 to "H" or "L". When power supply is turned on, or hardware reset is released, pin number 15 is read to turn on in either 4-wire/5-wire mode.

Mode	Pin number 15
4-wire touch screen	GND
5-wire touch screen	Vcc

### 4-3. Power supply voltage setting

Power supply mode setting for 3.3V/5V is performed by setting pin number 25 to "H" or "L". When power supply is turned on, or hardware reset is released, pin number 25 is read to turn on in either 3.3V mode/5V mode.

Power supply voltage	Mode	Pin number 25
3.3 to 4.0V	3.3V mode	Vcc
4.0 to 5.5V	5V mode	GND

\*When you operate it with 3.3V mode, the inside frequency of CPU works at 3MHz, and the sampling rate is 80pps max in calibration data mode.

## 5. Data sheet

### 5-1. Absolute maximum rating

Item	Symbol	Rating		Unit	Description
		Minimum	Maximum		
Power supply voltage	V <sub>CC</sub>	-0.3	6.5	V	
Input voltage	V <sub>I</sub>	-0.3	V <sub>CC</sub> +0.3	V	
Output voltage	V <sub>O</sub>	-0.3	V <sub>CC</sub> +0.3	V	
Power consumption	P <sub>D</sub>		200	mW	
Operation temperature	T <sub>OPR</sub>	-20	+85	°C	
Storage temperature	T <sub>STG</sub>	-40	+125	°C	

## 5-2. Recommended operational conditions

(V<sub>CC</sub>=3.3 to 5.5V, V<sub>SS</sub>=0V, T<sub>a</sub>=-20 to 85°C, unless otherwise noted)

Item	Symbol	Limits			Unit	Description
		Minimum	Standard	Maximum		
Power supply voltage	V <sub>CC</sub>	3.3	5.0	5.5	V	
Power supply voltage	V <sub>SS</sub>		0		V	
Analog reference voltage	V <sub>REF</sub>	1.8		V <sub>CC</sub>	V	
"H" input voltage (Pin number 1 - 4, 12 - 32)	V <sub>IH</sub>	0.8V <sub>CC</sub>		V <sub>CC</sub>	V	
"H" input voltage RST, XIN	V <sub>IH</sub>	0.8V <sub>CC</sub>		V <sub>CC</sub>	V	
"L" input voltage (Pin number 1 - 4, 12 - 32)	V <sub>IL</sub>	0		0.2V <sub>CC</sub>	V	
"L" input voltage RST, CNVSS	V <sub>IL</sub>	0		0.2V <sub>CC</sub>	V	
"L" input voltage XIN	V <sub>IL</sub>	0		0.16V <sub>CC</sub>	V	
"H" total peak output current *2 (Pin number 1 - 4, 12 - 32)	ΣI <sub>OH</sub> (peak)			-80	mA	
"L" total peak output current *2 (Pin number 1 - 4, 26 - 32)	ΣI <sub>OL</sub> (peak)			80	mA	
"L" total peak output current *2 (Pin number 12 - 25)	ΣI <sub>OL</sub> (peak)			80	mA	
"H" total average output current*2 (Pin number 1 - 4, 12 - 32)	ΣI <sub>OH</sub> (avg)			-40	mA	
"L" total average output current*2 (Pin number 1 - 4, 26 - 32)	ΣI <sub>OL</sub> (avg)			40	mA	
"L" total average output current*2 (pin number 12 - 25)	ΣI <sub>OL</sub> (avg)			40	mA	
"H" peak output current *3 (Pin number 1 - 4, 12 - 32)	I <sub>OH</sub> (peak)			-10	mA	
"L" peak output current *3 (Pin number 1 - 4, 12 - 32)	I <sub>OL</sub> (peak)			10	mA	
"H" average output current *4 (Pin number 1 - 4, 12 - 32)	I <sub>OH</sub> (avg)			-5	mA	
"L" average output current *4 (Pin number 1 - 4, 12 - 32)	I <sub>OL</sub> (avg)			5	mA	
Vibration frequency	XIN			6.0	MHz	

\*1 V<sub>CC</sub> = 4.0 to 5.5V

\*2 The total output current is the sum of all the currents flowing through all the applicable ports. The total average current is an average value measured over 100ms. The total peak current is the peak value of all the currents.

\*3 The peak output current is the peak current flowing in each port.

\*4 The average output current I<sub>OL</sub>(avg), I<sub>OH</sub>(avg) in an average value measured over 100ms.

\*5 When the oscillation frequency has a duty cycle of 50%.

5-3. Timing requirement

§ Reset

(Vcc = 3.3 to 5.5V , Vss = 0V , Ta = -20 to 85°C)

Item	Symbol	Limits		Unit	Description
		Minimum	Maximum		
RST L width	tw	2		μs	

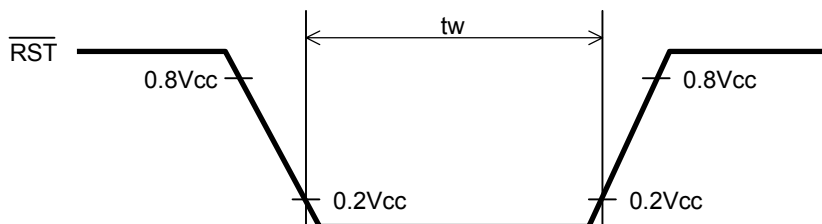

§ External clock timing

Item	Symbol	Limits		Unit	Description
		Minimum	Maximum		
Input cycle	tc	165		ns	Clock frequency: Fixed to 6MHz
Clock pulse width	tWH, tWL	70		ns	

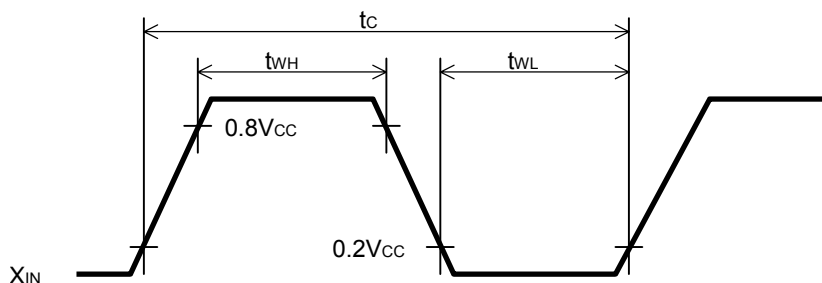

§ Clock input circuit

Using ceramic vibrator

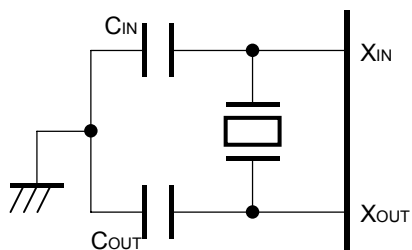

External clock input circuit

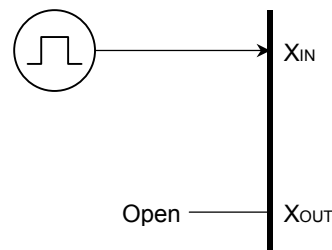

## 5-4. DC standards

(V<sub>CC</sub>=3.3 to 5.5V, V<sub>SS</sub>=0V, T<sub>a</sub>=-20 to 85°C, unless otherwise noted)

Item	Symbol	Condition	Limits			Unit
			Minimum	Standard	Maximum	
Output "H" voltage *1 (Pin number 1-4, 12-32)	V <sub>OH</sub>	I <sub>OH</sub> = -5mA V <sub>CC</sub> = 4.0 to 5.5V	V <sub>CC</sub> -1.5			V
		I <sub>OH</sub> = -1.0mA V <sub>CC</sub> = 3.3 to 5.5V	V <sub>CC</sub> -1.0			
Output "L" voltage *1 (Pin number 1-4, 12-32)	V <sub>OL</sub>	I <sub>OL</sub> = 5mA V <sub>CC</sub> = 4.0 to 5.5V			1.5	V
		I <sub>OL</sub> = 1.5mA V <sub>CC</sub> = 4.0 to 5.5V			0.3	
		I <sub>OL</sub> = 1.0mA V <sub>CC</sub> = 3.3 to 5.5V			1.0	
Output "L" voltage (Pin number. 12 - 16)	V <sub>OL</sub>	I <sub>OL</sub> = 15mA V <sub>CC</sub> = 4.1 to 5.5V			2.0	V
		I <sub>OL</sub> = 1.5mA V <sub>CC</sub> = 4.1 to 5.5V			0.3	V
Hysteresis (Pin number 12, 15, 17-26, 30)	V <sub>T+</sub> - V <sub>T-</sub>			0.4		V
Hysteresis (Pin number 26, 28)	V <sub>T+</sub> - V <sub>T-</sub>			0.5		V
Hysteresis (Pin number 6)	V <sub>T+</sub> - V <sub>T-</sub>			0.5		V
Input "H" current (Pin number 1-4, 12-32)	I <sub>IH</sub>	V <sub>I</sub> = V <sub>CC</sub>			5.0	μA
Input "H" current (Pin number 6)	I <sub>IH</sub>	V <sub>I</sub> = V <sub>CC</sub>			5.0	μA
Input "H" current (Pin number 9)	I <sub>IH</sub>	V <sub>I</sub> = V <sub>CC</sub>		4.0		μA
Input "L" current (Pin number 1-4, 12-32)	I <sub>IL</sub>	V <sub>I</sub> = V <sub>SS</sub>			-5.0	μA
Input "L" current (Pin number 6)	I <sub>IL</sub>	V <sub>I</sub> = V <sub>SS</sub>			-5.0	μA
Input "L" current (Pin number 9)	I <sub>IL</sub>	V <sub>I</sub> = V <sub>SS</sub>		-4.0		μA
Power supply current	I <sub>CC</sub>	STOP mode		0.1	1.0	uA

## 6. Packaging Specification

### 6-1. Outline

With a basic packaging unit of 2000, TSC-40/IC is packaged for the number of 2000 and its multiple using damp-proof aluminum laminate bags (Basic packaging). If the delivery quantity is less than 2000 or not multiple of 2000, or the product can not be packaged with a unit of 2000, then damp-proof aluminum laminate bags or no damp-proof packaging specification is applicable (Small group packaging).

If packaged with small group packaging, the products may be dampened. Before packaging, the product shall take the baking process as specified in [Baking] defined in "TSC-40/IC Storage/Implementation Specification".

### 6-2. Notes on storage/handling

- (1) Handle the packages with care and avoid throwing and dropping them. Or, a large impact may be imposed, causing packaging material's damage, broken package or bending lead.
- (2) Cardboard box may be deteriorated in its strength and deformed due to storage site's humidity, stacking condition and storage duration. It is desirable to keep the storage under normal temperature/humidity (5 to 35 °C, 45 to 75%RH). For warehousing, follow the FIFO principle.
- (3) After unpacking, be careful in handling the product to avoid electrostatic breakdown.

### 6-3. Basic packaging

#### 6-3-1. Packaging type

Damp-proof packaging (Aluminum laminate bag)

#### 6-3-2. Packaging quantity specification

Quantity per tray	Number of trays	Quantity per packages
250	8 + 1(cover)	2000

#### Packing sample

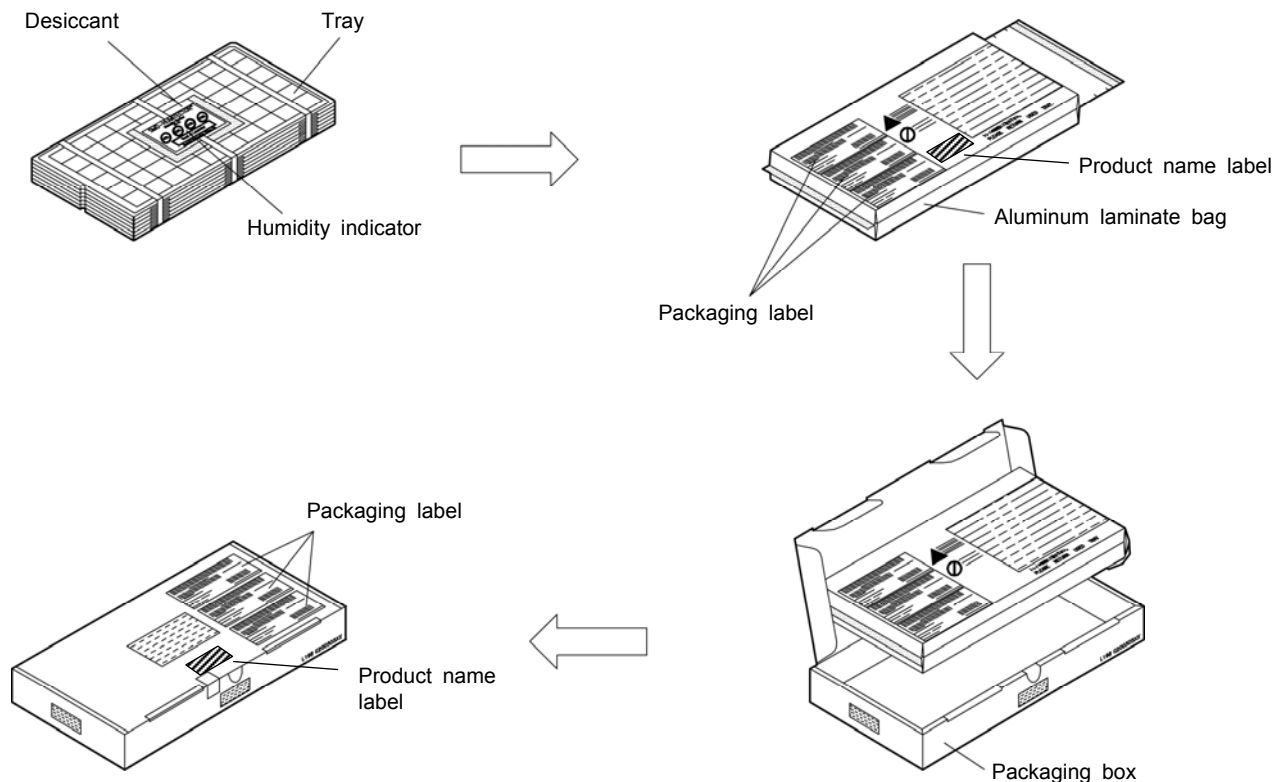

6-3-3. Diagram for packaging box sizes

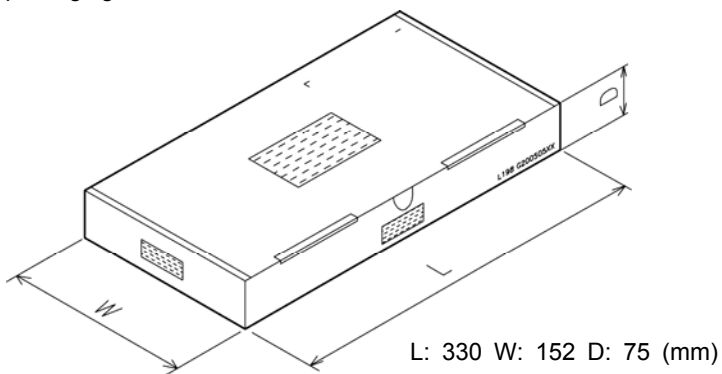

6-4. Small group packaging

6-4-1. Packaging type

General packaging (No damp-proof processing)

6-4-2. Packaging quantity specification

Quantity per tray	Number of trays	Quantity per packages
250	1 to 8 +1(cover)	1 - 1999

Packing sample

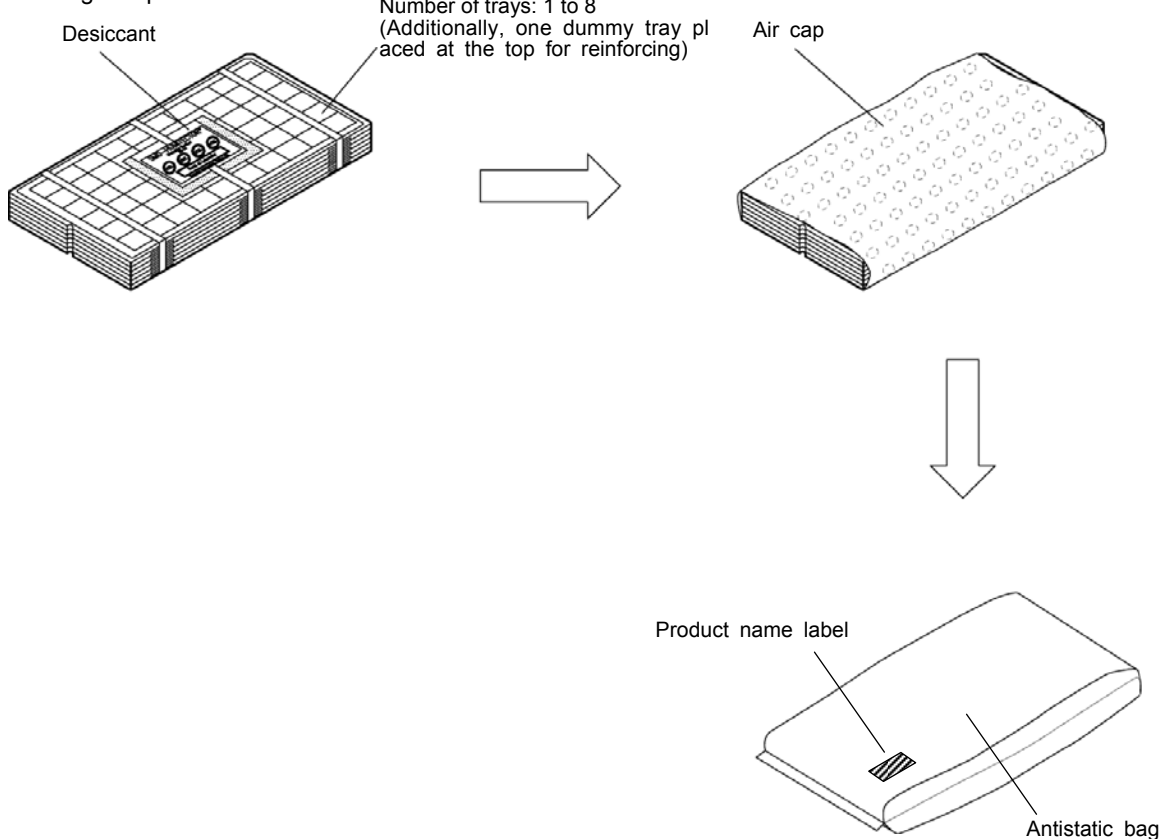

\* No sizes specified for packaging box (Cardboard box) used for transportation.

\* This is an example and may not be the same as supplies.

**6-5. Tray specification**

This tray is heat-proof type, allowing the heating with 125 °C for 24 hours. During heating/cooling process, however, bending may occur. In baking process, to minimize the bending, heat and cool the tray by placing it on a flat plate.

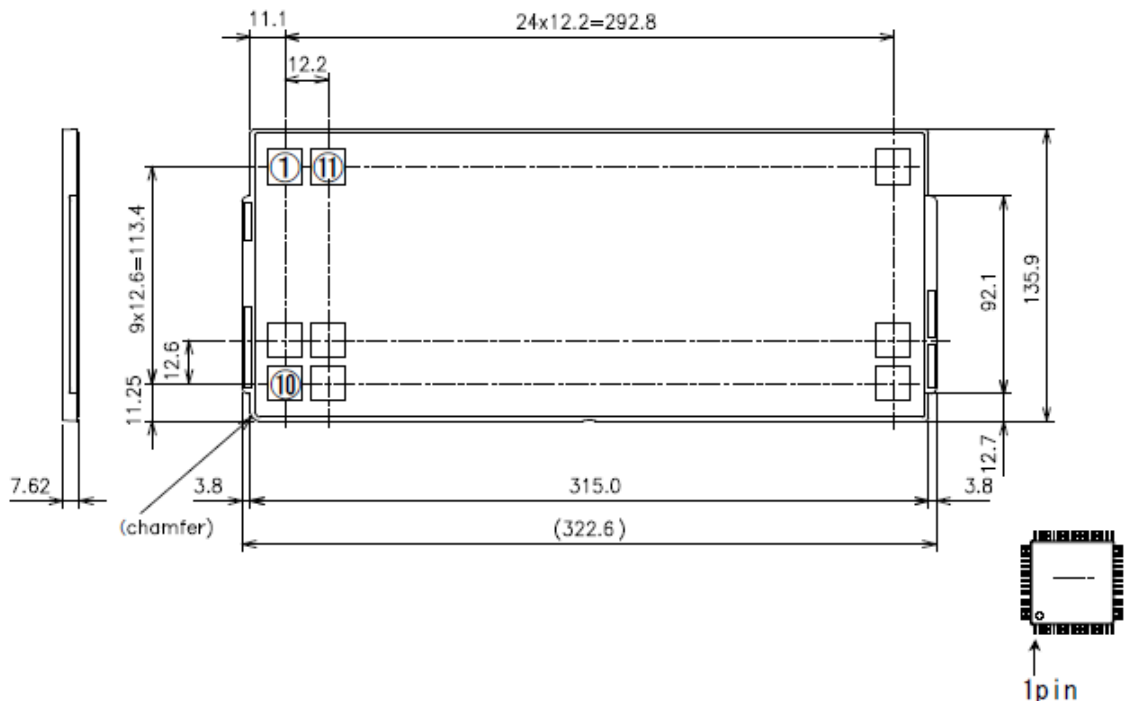

**6-6. Product name label specification**

- DMC P/N: Product number (TSC-40/IC)
- QTY: Quantity
- DAC: DMC Control Number

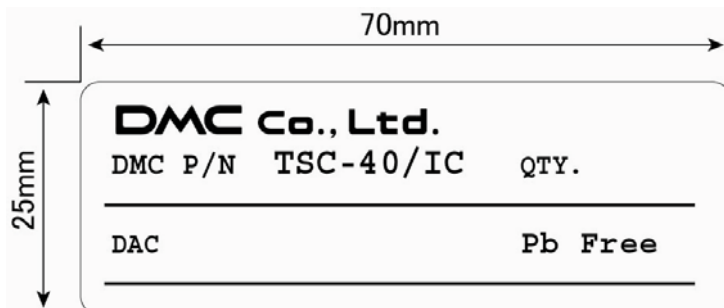

## 7. Storage Specification

### 7-1. Storage Conditions

For storing the product until its implementation, it is recommended that the following storage conditions are applied:

1. Before unpacking the damp-proof package (Aluminum laminate bag)

Temperature and humidity: 5 to 40 °C, 20 - 80%RH

Duration: Two years or less

2. After unpacking the damp-proof package (Aluminum laminate bag)

For the storing duration after the damp-proof package is unpacked and before the implementation, it is recommended that the following storage conditions is to be applied:

(1) Reflow method: One week or less under the ambient condition: 30 °C, 70%RH or less

(2) Wave soldering method: One week or less under the ambient condition: 30 °C, 70%RH or less

3. Temporary storage after damp-proof package is unpacked

To store again temporarily the once unpacked and unused damp-proof package, it is recommended to pack it again into another damp-proof bag with desiccant within a shorter time after opened (Around 10 minutes) as far as possible, and fold the bag's opening, followed by sealing with adhesive material such as adhesive tape, then store it under the following conditions:

Temperature, humidity: 5 to 40 °C, 20 - 80%RH

Duration: One month or less

### 7-2. Baking

If any condition among those 1 to 3 listed below is applicable, it is recommended to apply the baking as described below to dry the moisture the package absorbs.

You may place the tray used for damp-proof packaging directly into the thermostatic chamber since the tray is heat-proof type. When placing into the chamber or after removing from it, to avoid deformation, cool the tray by placing it on the flat plate such as surface table.

1. Any condition among 1 to 3 in [7-1. Storage condition] is unsatisfied
2. Indicator's 30% Humidity Check section changes the color to lavender or pink
3. Blue color indicator of desiccant (Silica gel) changes to pink or white

Baking method

Temperature: 125 °C

Duration: 20 to 24 hours

Frequency: Four times or less (Upper limit: 96 accumulative hours)

## 8. Implementation Temperature Specification

### 1. Reflow method (Infrared reflow, air reflow)

Frequency: Three times or less

Temperature: The following device surface temperature profile is recommended.

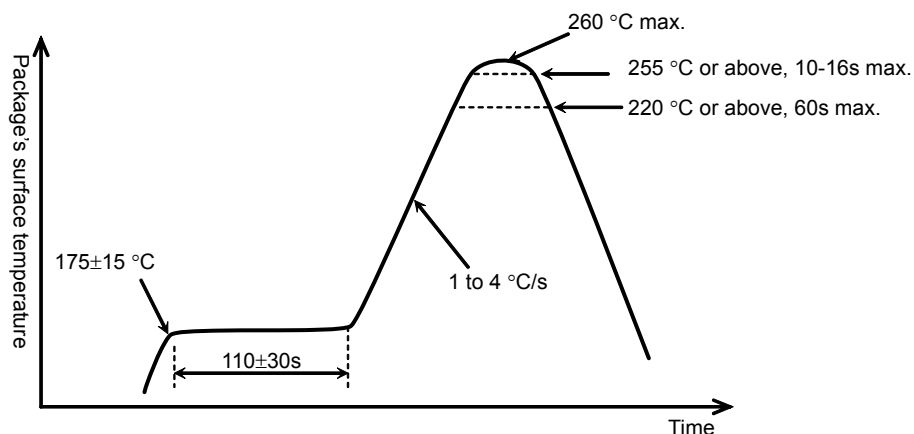

Figure 1: Infrared reflow, air reflow temperature profile

### 2. Wave soldering method (Flow soldering, solder dip method)

Frequency: One time or less

Temperature: Following temperature profile is recommended (Set the optimal preheat temperature according to the flux type)

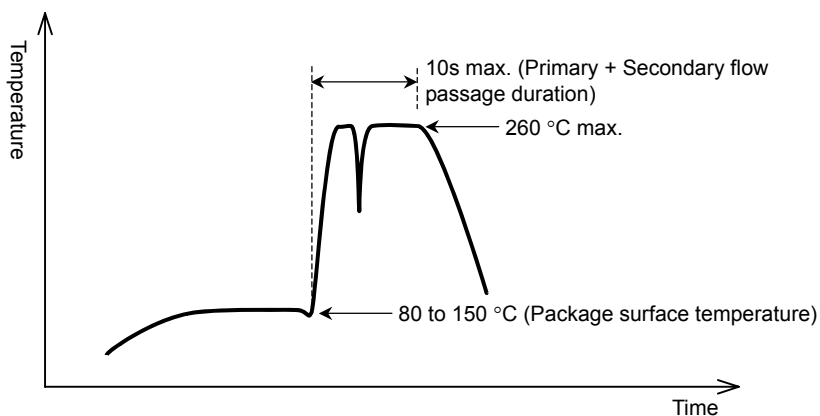

Figure 2: Wave soldering temperature profile

### 3. Soldering iron (Manual soldering)

Soldering bit's temperature:  $370 \text{ }^\circ\text{C}$  or lower

Soldering time: Five seconds or less/terminal

**9. Terminal Pin Specification**

Base material	:Cu
Coat	:Sn-1.5%Cu
Thickness of coat	:5um or above

**10. Cleaning**

In case of cleaning boards with solvents after soldering, following items should be taken attention.

- \*Administrative guidance and regulation.
- \*Residual ionic (non ionic) contamination.
- \*Solvent resistance of parts.

## 11. Changes and improvements

### 11-1. Version history

#### § TSC-40/IC

Ver0.1 (October 3, 2007)

Draft release

Ver0.2 (December 10, 2007)

5-3. Timing requirement      External clock timing      Clerk mistake was corrected.  
Input cycle 500ns → 166ns  
Clock pulse 200ns → 70ns

6-6. Product name label specification      "Pb Free" was added.

Ver0.3 (January 21, 2008)

Circuit Diagram    5-Wire Resistive Touch Screen

Corrected the 15<sup>th</sup>-Pin (SEL3/EEP\_CLK) to connection with Vcc via resistance.

Ver1.0 (March 13, 2008)

First release

(Change from ver0.3)

1-4. General specification    Input response time was added.  
3. Pin functions    Detail information was added in 22, 23, 24 pin.  
9. Terminal Pin Specification was added.  
Document number was added.  
Circuit Diagram    Part number was added. (Rev 2)

Ver1.1 (June 30, 2008)

5-2. Recommended operational conditions    (TTL input level selected) was deleted.

Ver1.2 (July 2, 2008)

1-4. General specification    Power supply voltage DC 2.4V to 5.5V → DC 3.3V to 5.5V

Ver1.3 (March 30, 2011)

5-3. External clock timing    "Input cycle" (Minimum) 166ns → 165ns  
6-1. Outline (Small group packaging)    "damp-proof aluminum laminate bags or" was added.  
6-3. Basic packaging    "Packing sample" was added.  
6-4. Small group packaging    "Packing sample" was added.  
6-4. Small group packaging    "This is an example and may not be the same as supplies." was added.

## **12. Warranty**

### **12-1. Warranty Period**

- § The warranty period is limited to 1 year from the date of shipping. The warranty for the initial deflection such as appearance deflection is limited to 1 month.
- § Any defected parts under proper use will be examined by the supplier and replaced by the new parts if the deflection is considered to be caused by the supplier.
- § The replacement is subject to be included in the next lot.

### **12-2. Warranty Target**

- § The warranty only covers the product itself and does not cover any damage to others caused by using this product. Onsite repair or replacement is not supported.
- § We will do our best for delivery problem and product defections, but the warranty for the production line is not covered.

### **12-3. Warranty Exceptions**

Following conditions are not covered with the warranty and subject to charge.

- § Any malfunctions and damages during transportation and transfer by the user.
- § Any malfunctions and damages caused by a natural disaster or a fire.
- § Any malfunctions and damages caused by static electricity
- § Any malfunctions and damages caused by the failure of the associated equipment.
- § If the product is remodeled, disassembled or repaired by the user.
- § If the product is glued onto the equipment and uninstalled.
- § Any malfunctions and damages caused by an improper usage and handling against the specifications and notes.

### **13. Notes on use**

#### **13-1. Overall handling**

- § When using the product, do not place it close to, or make it contact with, the conductive materials such as metal.
- § Do not touch the metal part in the product directly with your hands. Or, it may be destructed by the static electricity. If you contact, or may contact, it directly with your hand, prepare in advance the measure against static electricity.
- § To store the product, use an appropriate packing box and keep the storage temperature range with no overload on it.
- § In using the product or storing it, avoid the following conditions:
  - Conditions where water is, or may be, attached to the product.
  - Conditions where condensation takes place, or may take place.
  - In the ambience of organic solvent or acidity or contact, or where the product contacts them.
- § Do not alter or disassemble the product.

#### **13-2. Others**

- § This specification may be changed for improvement without prior notices.
- § No liabilities are taken by us for any damage caused by use of this product.
- § This product intends to be used for the standard applications (e.g. office equipment and OA devices, industrial use, communication devices, household equipment). Avoid its use where failure or malfunction directly may affect the human body or special applications where extremely high reliability is required (e.g. airline and space industries, nuclear controls, medical use for life-sustaining).
- § Semi-conductor devices may fail in a certain possibility. Keep the safety design in your mind so that possible failure in this product shall not cause physical accidents such as injury and death, fire and other social damages.

TSC-40/IC Product Specification  
Version 1.3: Issued at March 30, 2011  
©2011 DMC Co., Ltd.

This document is allowed to redistribute but no alteration, part or all, is prohibited.

**DMC Co., Ltd.**

<http://www.dmccoltd.com/english/>  
9F Kanda Sent-Building 1-2-4, Yushima, Bunkyo-ku, Tokyo, 113-0034 Japan  
Phone: +81-3-5209-7131 (Japanese), 7135 (English) Fax: +82-3-5209-7130

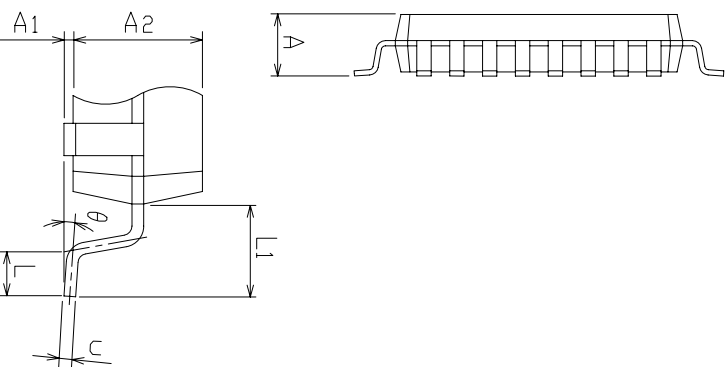
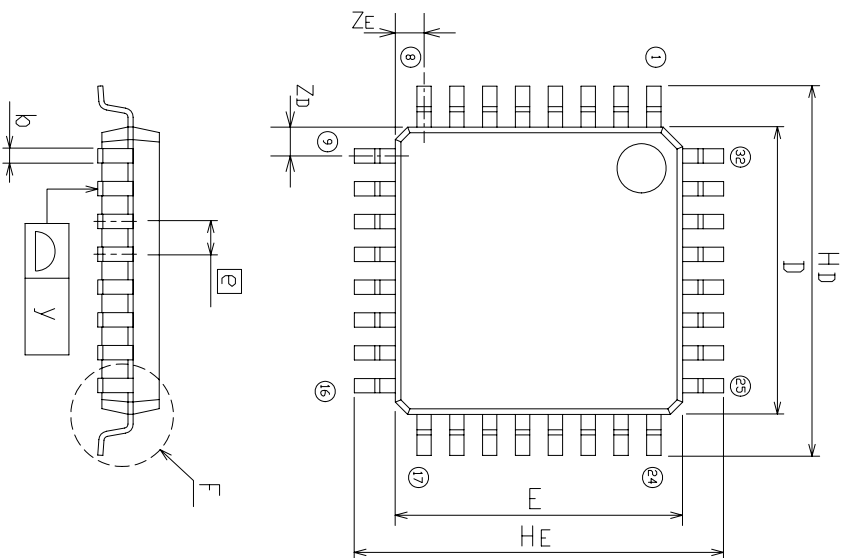

Symbol	Dimension in Millimeters		
	Min	Nom	Max
A	-	-	1.7
A1	0	0.1	0.2
A2	-	1.4	-
b	0.32	0.37	0.42
c	0.09	0.145	0.2
D	6.9	7.0	7.1
E	6.9	7.0	7.1
e	-	0.8	-
HD	8.8	9.0	9.2
HE	8.8	9.0	9.2
L	0.3	0.5	0.7
L1	-	1.0	-
$\gamma$	-	-	0.10
$\theta$	0°	-	8°
ZD	-	0.7	-
ZE	-	0.7	-

Detail F

Date	P/N
October 3, 2007	TSC-40/IC

Name  
Dimensional Drawing Rev 1

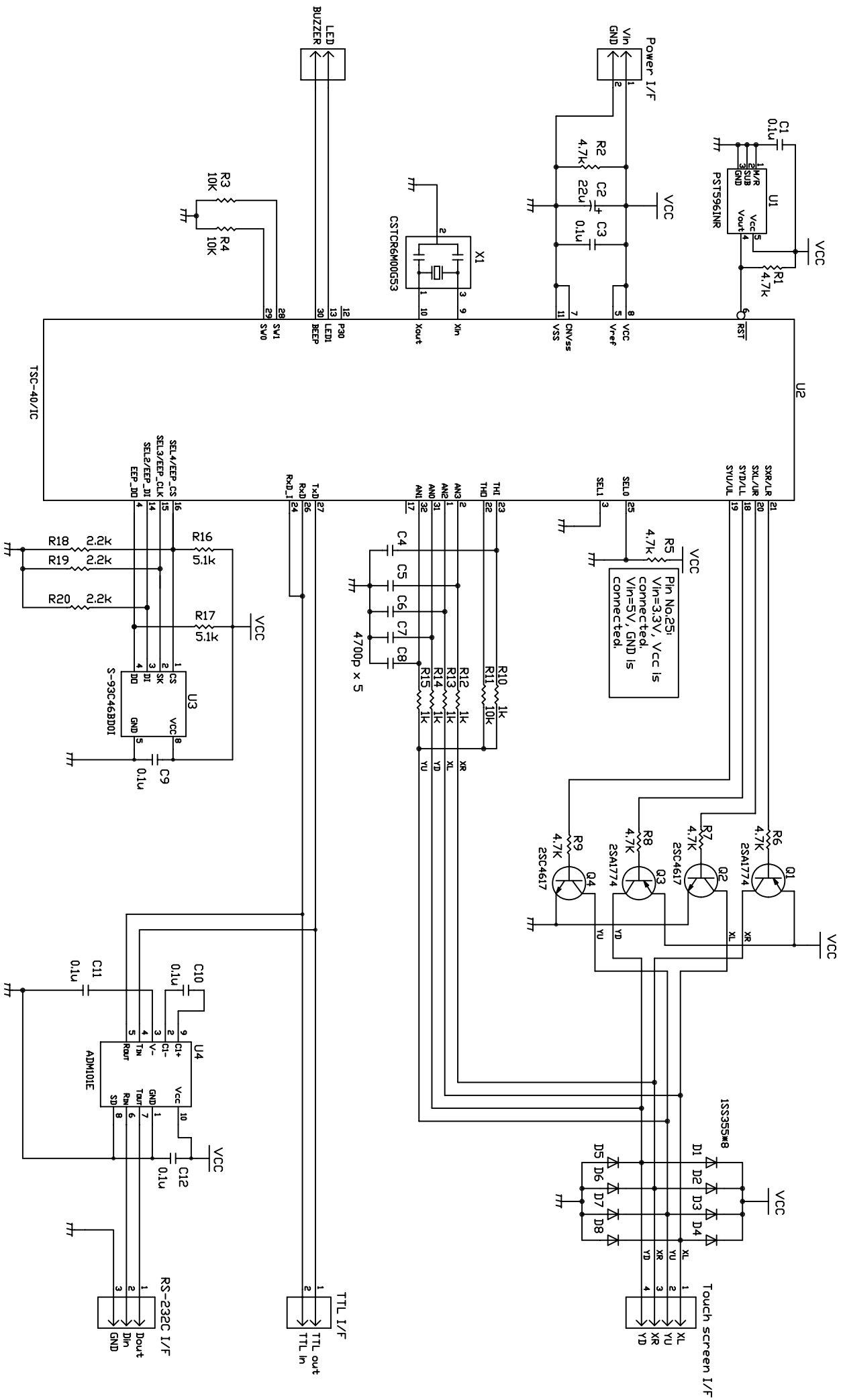

With EEPROM : Delete R16  
 Without EEPROM : Delete R18, U3, C9

This document is to be used as a reference guide only.  
 DMC assumes no liability for applications assistance or customer product design.  
 DMC does not warrant or represent that any license is granted under patent or other rights.

Date	P/N	Name
February 27, 2008	TSC-40/1C	4-Wire Resistive Touch Screen
	RS-232C I/F	Circuit Diagram Rev. 2

DMC Co., Ltd.

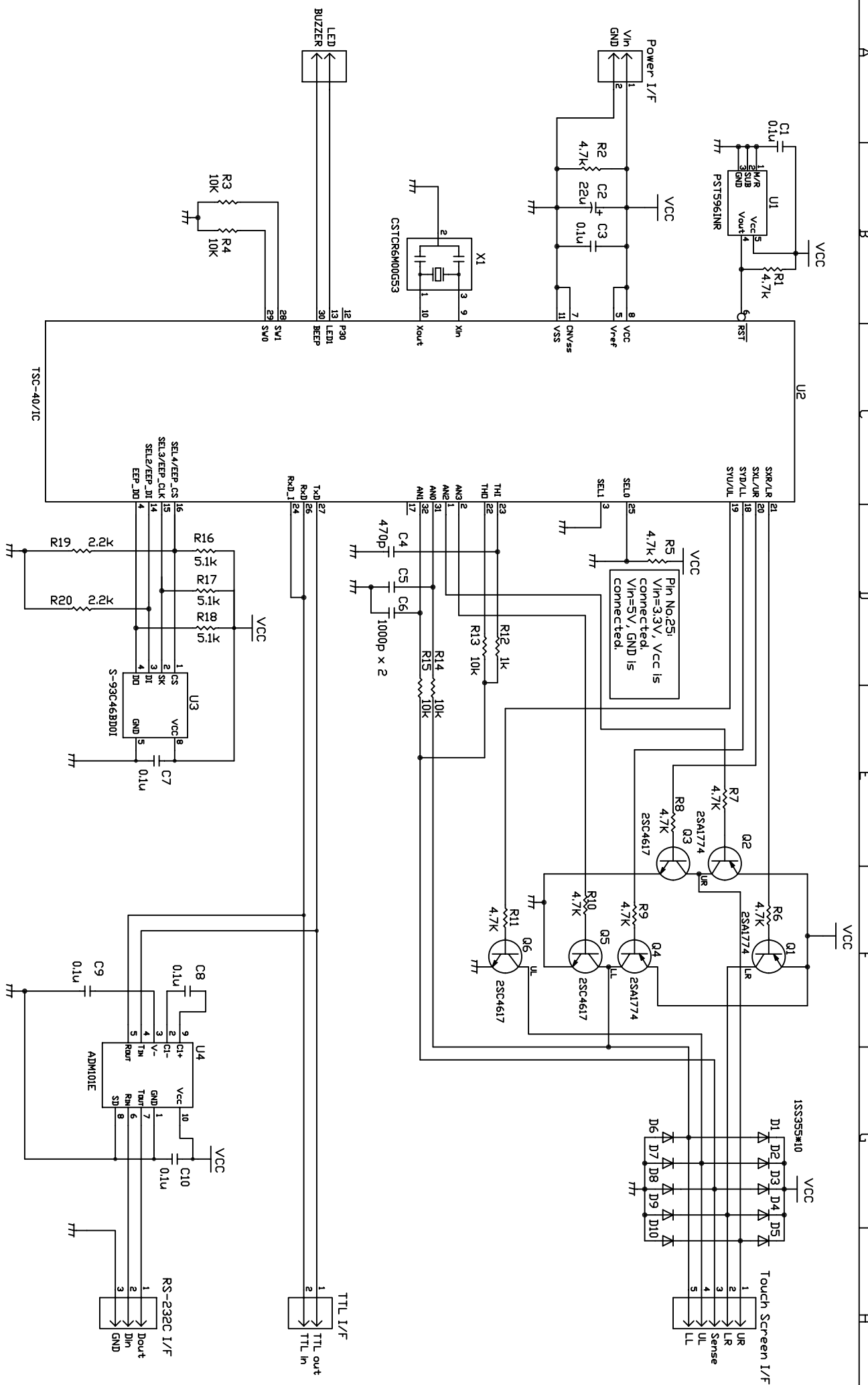

With EEPROM : Delete R16  
 Without EEPROM : Delete R19, U3, C7