

Contents in this document may change without prior notice.  
Please obtain the delivery specification for the final design.



10.1" Wide (WSVGA)

Resistive Touchscreen Module with LCD

Basic Set

# TK-B Series

Model: TK-BRA101WS-01A3

## Product Specification

DMC Co., Ltd.

<https://www.dush.co.jp/english/>

## Table of Contents

1	Summary .....	2
2	Product Model .....	2
3	Packaging Specification .....	3
4	Module Specification .....	4
4-1	Function .....	4
4-2	Environment .....	5
4-3	Mechanical Specification .....	5
4-4	Touchscreen Controller .....	5
4-5	Touchscreen Driver .....	5
4-6	HDMI Board .....	6
4-6-1	Support Timing .....	6
4-6-2	Part Names (HDMI Board).....	7
4-6-3	Image Input (HDMI) I/F .....	8
4-6-4	Touchscreen Control USB I/F.....	8
4-6-5	12VDC Power Input I/F .....	9
4-6-6	Pilot Lamp LED Control I/F.....	9
4-6-7	Pilot Lamp LED .....	9
5	Product Label .....	10
6	Compliant Standards .....	10
6-1	RoHS.....	10
7	Appearance inspection standard.....	10
8	Connecting Method .....	11
8-1	Connecting Each Cable to User I/F of HDMI Board.....	11
9	Touchscreen Calibration .....	12
9-1	Resistive Touchscreen .....	12
9-2	Gesture Correction (DO NOT PERFORM) .....	13
10	Terms of Use .....	14
10-1	Installing Resistive Touchscreen .....	14
10-2	Installing Module .....	15
10-3	Precautions for Use of LCD .....	15
10-4	Precautions for Resistive Touchscreen.....	15
10-5	Precautions for Static Electricity .....	16
10-6	Operating Precautions .....	16
10-7	Storing Precautions .....	16
10-8	Handling Precautions .....	16
11	Warranty .....	17
12	Production Discontinuance .....	17
13	Other .....	18

### Appendix

- Outline Drawing
- Resistive Touch Screen Mounting Guidance
- Touch Screen Controller Specification: TSC-52/U User's Guide
- Appearance inspection standard(LCD Modules with Resistive Touchscreen)

## 1 Summary

This is a “TK series Basic Set” with 10.1" Wide resistive touchscreen sensor, controller, LCD(Liquid Crystal Display), and HDMI board put together in a sheet metal chassis.

## 2 Product Model

Model	Specification		
	LCD size (Resolution)	Touchscreen Type	Set Type
TK-BRA101WS-01A3	10.1" Wide (WSVGA)	Resistive	Basic Set

### 3 Packaging Specification

Contents	Specification	Size (W x D x H)
TK-BRA101WS-01A3	Grouped packaging (5units/box)*	External Dimension: 300 x 300 x 290

※May not be as specified according to the quantity shipped.

#### • Grouped Packaging Configuration

No.	Name	Qty
①	TK-BRA101WS-01A3 (placed inside anti-static, air-cushion bag) ※Touchscreen with protective sheet	5
②	Individual box	5
③	Outer box	1
④	Top Pad	2
⑤	Packaging label	5
⑥	Grouped packaging label	1

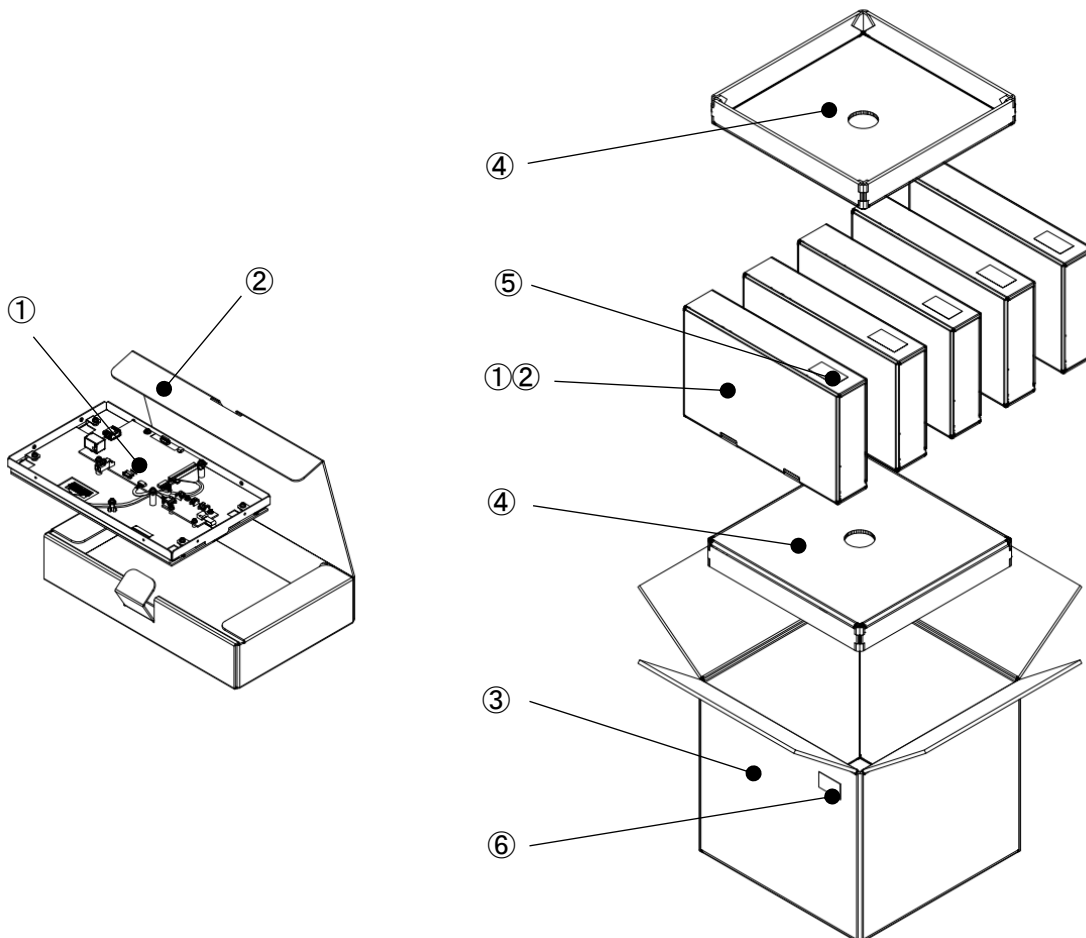

## 4 Module Specification

### 4-1 Function

Item		Specification	units	
LCD	Display device	10.1" Wide TFT LCD	-	
	Display area (Active area)	222.72(W) ×125.28(H)	mm	
	Pixels	1024(W) ×600(H)	-	
	Pixel pitch	0.2175(W) ×0.2088(H)	mm	
	Color	16.7M	colors	
	Brightness (Typ.)	360	cd/m <sup>2</sup>	
	View angle (Typ.)	Vertical (Upper/Lower)	60 / 60	deg.
		Horizontal (Left/Right)	70 / 70	
	Interface	LVDS	-	
	Backlight method	LED, with backlight driver	-	
	Backlight life* <sup>1</sup>	Min. 50,000	hours	
Touchscreen	Touchscreen type	Analog 4-wire resistive	-	
	Input method	Finger or R0.8 Polyacetal pen	-	
	Maximum simultaneous input point	1 point (supports gesture function)	-	
	Operating life	Continuous input (finger)	10,000,000	times
		Continuous input (pen)	100,000	characters
	Communication Method	USB 2.0	-	
Supporting OS* <sup>2</sup>	Microsoft® Windows® 10/11 (32bit/64bit)	-		
HDMI board	Input image port	HDMI (does not support HDCP)	-	
	Input Signal	Digital	HDMI 1.3b	
		Horizontal scan cycle	30K - 80K	Hz
		Vertical scan cycle	50 - 60	Hz
Module	Bonding method	Air-bonding (Bonding of LCD and touchscreen with double-sided tape.)	-	
	Input power voltage* <sup>3</sup>	12±5%	V	
	Energy consumption(Max.)	6	W	

※1 Time until brightness declines by 50% from the initial value at maximum brightness in ambient temperature of 25°C.

※2 Please contact us for information regarding OS other than Windows.

※3 If the capacity of the power supply used is large, the drop in voltage when it is turned off will be gradual. When restarting, please turn on the power again after the power supply voltage becomes 0V.

## 4-2 Environment

Item	Specification
Ambient operating temperature (Inside cabinet and display side)	0°C to 55°C
Ambient storage temperature	-20°C to 70°C
Ambient operating humidity	10%RH to 85%RH (Non-condensing. Wet-bulb temperature is 39 °C or less)
Ambient storage humidity	10%RH to 85%RH (Non-condensing. Wet-bulb temperature is 39 °C or less)
Dust	0.1mg/m <sup>3</sup> or under (Conductive dust is prohibited)
Corrosive Gas	Corrosive gas is prohibited
Pollution Degree	Pollution Degree 2, for indoor use

## 4-3 Mechanical Specification

Item	Specification
Mass	Approx. 770 g
External dimensions (excluding protruding parts)	244.0(W)×147.0(H)×(40.0)(D) mm

## 4-4 Touchscreen Controller

This is the Touchscreen controller with flick operation and 2-finger gesture (pinch-in/pinch-out and rotation)\* functions.

Please refer to the attached touchscreen specification for details.

※Two-finger touch input is a function to realize gesture operation, and position (coordinate) data at two-finger touch should not be used.

※When operating gestures, please keep a small distance between fingers.

## 4-5 Touchscreen Driver

In order to use the touchscreen, you will need to install a touchscreen driver (DMT-DD).

To obtain the driver, please download it from the following site.

URL: <https://www.dush.co.jp/english/download/>

Download > Driver-App > Touchscreen Related > Touchscreen Driver.

For DMT-DD installing directions, please refer to the User's Guide included in the downloaded files.

## 4-6 HDMI Board

### 4-6-1 Support Timing

No	Resolution	Aspect Ratio	Refresh Rate
1	640×480p	4: 3	60Hz
2	720×480p	4: 3	60Hz
3	800×600p	4: 3	56Hz
4	800×600p	4: 3	60Hz
5	1024×768p	4: 3	60Hz
6	1280×720p	16: 9	60Hz
7	1280×960p	4: 3	60Hz
8	1280×1024p	5: 4	60Hz
9	1600×900p	16: 9	60Hz
10	1600×1200p	4: 3	60Hz
11	1680×1050p	16: 10	60Hz
12	1920×1080p	16: 9	60Hz

#### 4-6-2 Part Names (HDMI Board)

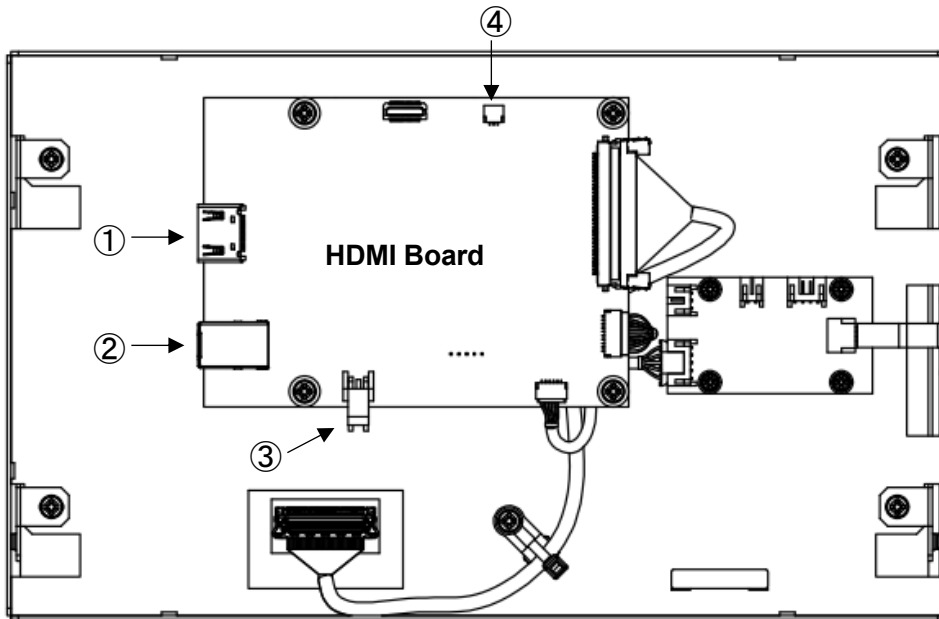

No.	Interface Name
①	Image input (HDMI)
②	Touchscreen control USB (USB 3.0 Type-B) ※1
③	12VDC Power input (Nylon connector)
④	Pilot lamp LED control

※1 USB2.0 Type-B can be connected.

※2 Use of other connectors not listed is prohibited. They are for internal adjustments only and may be excluded without prior notice.



### 4-6-3 Image Input (HDMI) I/F

Connector No.: CN7

Interface: HDMI Type A

※HDMI standard compliant

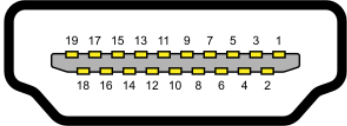
PIN No	Signal Name	PIN No	Signal Name	Schematic Diagram
1	TMDS Data2+	11	TMDS Clock Shield	
2	TMDS Data2 Shield	12	TMDS Clock-	
3	TMDS Data2-	13	CEC (NC)	
4	TMDS Data1+	14	Reserved	
5	TMDS Data1 Shield	15	DDC Clock	
6	TMDS Data1-	16	DDC Data	
7	TMDS Data0+	17	DDC GND	
8	TMDS Data0 Shield	18	+5V Power	
9	TMDS Data0-	19	Hot Plug Detect	
10	TMDS Clock+	-	-	

### 4-6-4 Touchscreen Control USB I/F

Connector No.: CN4

Interface: USB3.0

Connector: USB3.0 Type-B

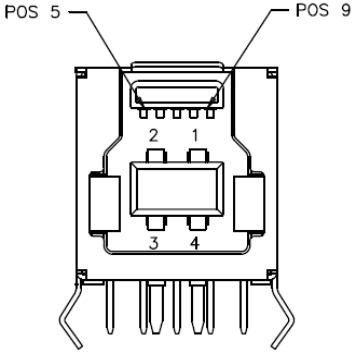
PIN No.	Signal Name	Description	Schematic Diagram
1	VBUS (5V)	Power	 <p>View from connector inserting side</p>
2	D-	USB 2.0	
3	D+		
4	GND	GND for power return	
5	StdB_SSTX-	SuperSpeed transmitter	
6	StdB_SSTX+		
7	GND_DRAIN	GND for signal return	
8	StdB_SSRX-	SuperSpeed receiver	
9	StdB_SSRX+		
10	Shield		

\* USB port for touchscreen control (can be connected to USB2.0 Type-B).

#### 4-6-5 12VDC Power Input I/F

Connector No.: CN1

Interface: +12VDC Input

Connector: A3963WR2-2P(JWT)

※Equivalent to S2P-VH(JST)

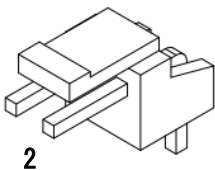
PIN No.	Signal Name	Schematic Diagram
1	+12V	
2	GND	

#### 4-6-6 Pilot Lamp LED Control I/F

Connector No.: CN10

Connector: 1010-SMTR-03P(JWT)

※Equivalent to SM03B-SRSS-TBT (JST)

PIN No.	Signal Name
1	LED_G※
2	GND
3	LED_R※

※Power supply 3.3V, limiting resistance 220Ω (board built-in)

#### 4-6-7 Pilot Lamp LED

By preparing a LED board (refer to following circuit board diagram), the power of the HDMI board and the status of the image input signal can be indicated by LED.

##### ▪ Status Indicating LED (Example)

Green lit: Power ON, with image input signal

Orange lit: Power ON, without image input signal.

LED off: Power OFF

##### ▪ Circuit diagram (Example)

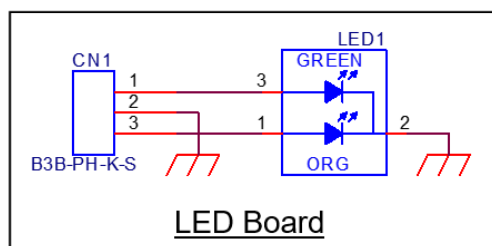

## 5 Product Label

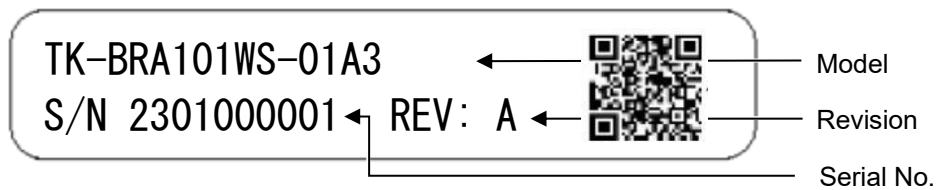

Above is an image example of the product label.

Below information will be indicated on the actual product.

- Model: Product Model
- Serial No.: 10 digit control number
- Revision: Alphabets (A to Z) according to the product revision

## 6 Compliant Standards

### 6-1 RoHS

Compliant to EU RoHS directives.

## 7 Appearance inspection standard

Please refer to “Appearance inspection standard(LCD Modules with Resistive Touchscreen)” (22G4GX-00001E) for standards.

## 8 Connecting Method

### 8-1 Connecting Each Cable to User I/F of HDMI Board

(1) Connecting the HDMI cable and the USB cable.

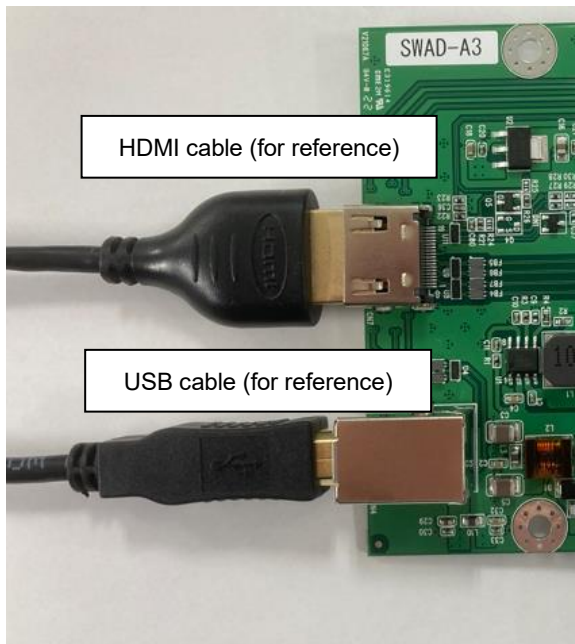

※Please insert securely.

※HDMI cable/ USB cable not included.

(2) Connecting the Power cable.

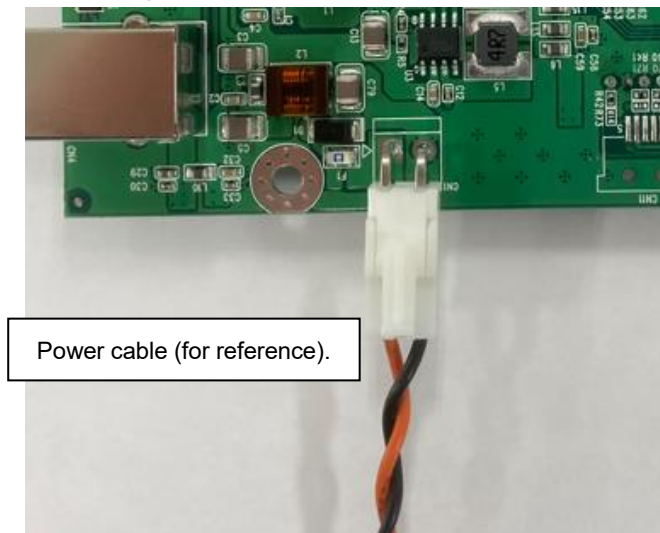

※Please insert securely.

※Power cable not included.

## 9 Touchscreen Calibration

Touch screen operations may become unstable depending on the installation environment due to its characteristics. To use it correctly, please perform calibration when building into a device.

Install DMT-DD from "[4.5. Touchscreen Driver](#)" when calibrating.

### 9-1 Resistive Touchscreen

[4-point correction] or [9 point correction] ...Coordinate calibration.

- (1) Start DMT-DD.
- (2) Choose the [Software Setting] tab via [Basic Setting]

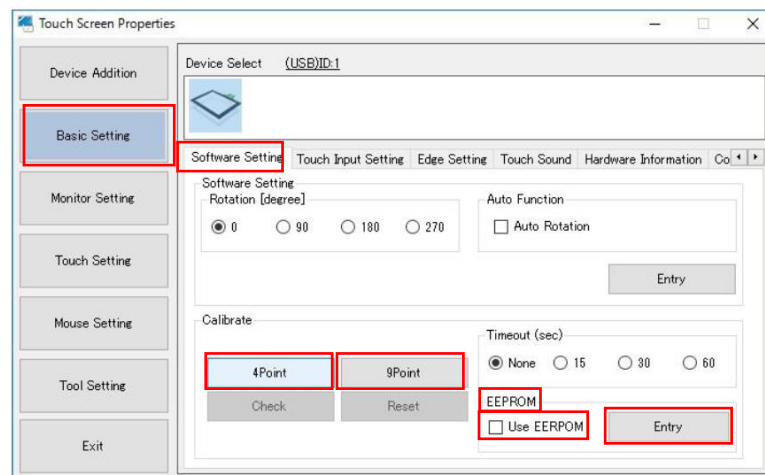

- (3) Click and place a check in the box next to [Use] under [EEPROM] and click [Register].  
When [4 Point Correction] or [9 Point Correction] is performed with the check in the box, the correction data will be stored in the EEPROM of the Product.

When performed without the check, then the correction data will be stored inside the computer.

[4 Point Correction] is conducted to the Product at shipment from the factory and the correction data is stored in the EEPROM.

Placing the check will recall the data from the EEPROM and correction will not be necessary.

If touch coordinates are out of alignment, please follow the procedure below and perform coordinate calibration.

When correction is performed without placing the check, the correction data at factory shipment will not be reflected and accurate touch operation may not be possible.

- (4) Below adjustment screen will be displayed when [4 point correction] or [9 point correction] is clicked.

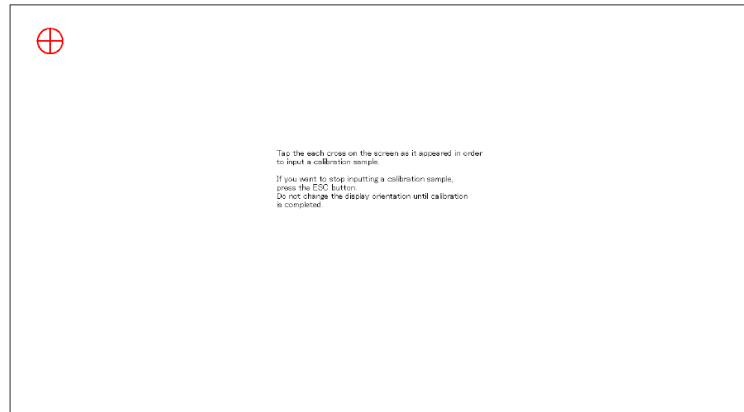

- (5) Touch the center of the marker displayed on the screen. Another marker will be displayed one after another. Do the same for all.
- (6) After all markers have been touched, adjustment is completed and the following screen will be displayed.

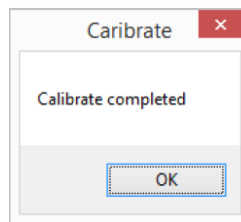

- (7) Click [OK] to finish the adjustment.

## 9-2 Gesture Correction (DO NOT PERFORM)

Gesture correction is performed at the factory before shipment and does not need to be performed.

If gesture correction is performed, touch operation may not work properly.

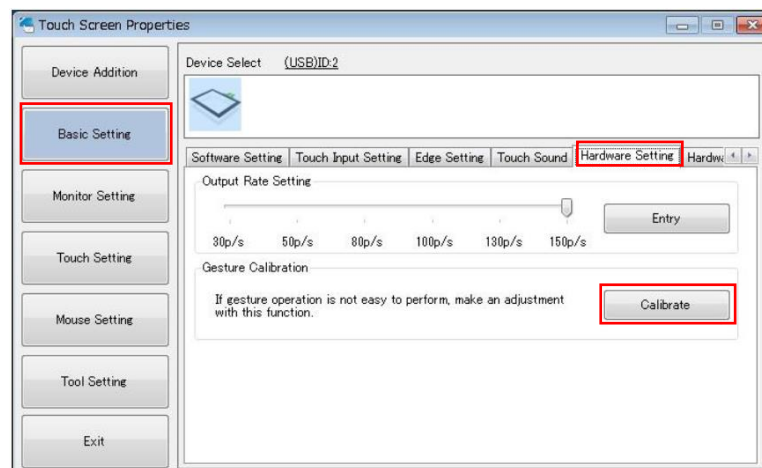

## 10 Terms of Use

### 10-1 Installing Resistive Touchscreen

(1) When opening the entire surface of the touchscreen and applying sheet to the surface

- Design and adjust the touchscreen surface slightly offset from the sheet surface (about 0.3mm recommended) in order to avoid the sheet surface from pressing on the touchscreen.
- To avoid damage to the LCD (Liquid crystal display) and FPC tail of the touchscreen, make sure they do not come in direct contact with the edge of the panel openings. If damaged, display and touchscreen may not operate properly.

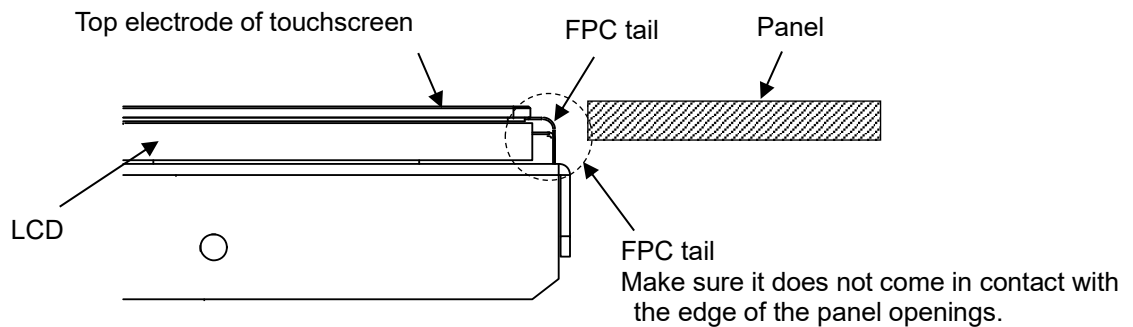

(2) If Bezel Come on Top of Touchscreen Surface

- Be sure to keep a clearance of 0.5 mm or more between the inside of the bezel and the upper electrode of the touchscreen to avoid input errors caused by strains of the bezel when hands are placed on it.
- When placing cushions between the inside of the bezel and the upper electrode of the touchscreen, be sure to have some allowance to absorb the expansion/contraction differences between them due to temperature change. If the cushion is pressed down strongly, it may not be able to absorb the expansion/contraction and may cause distortion or deflection of the electrode which may affect both appearance and function. The cushioning material must be installed 1.0 mm or more outward from the edge of the insulation area.

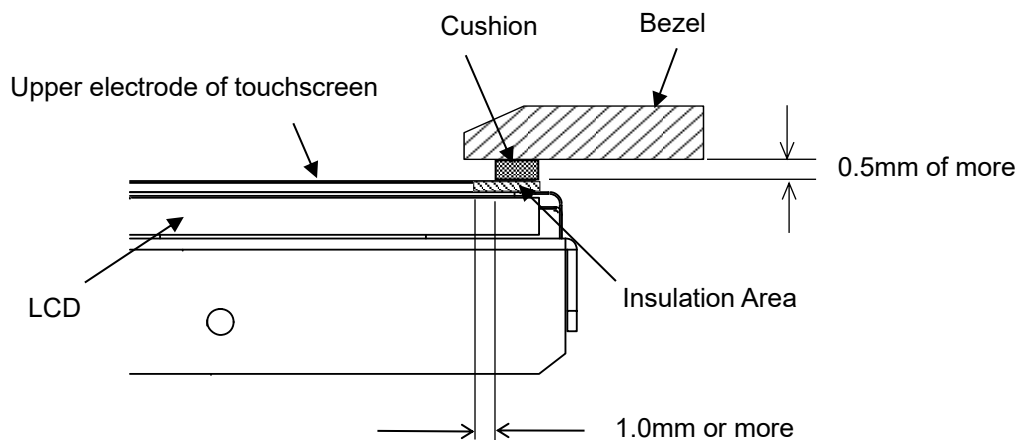

## 10-2 Installing Module

- (1) For stable brightness and display, connect the GND via the mounting hole on the LCD.
- (2) Mount the LSI so that no external pressure is applied to the LSI mounting area.
- (3) Make sure there are no warping and twisting when installing.
- (4) Make sure the specified temperature and humidity between the module and structure or parts is taken into consideration to secure ventilation.
- (5) Take anti-static measures such as wearing grounding arm bands during assembly.
- (6) To prevent malfunction or damage, make sure the connector of connecting cable is inserted securely.
- (7) Remove the protection sheet on the touchscreen when installing.

## 10-3 Precautions for Use of LCD

- (1) The LCD contains irritants inside. If by any chance the liquid should flow out due to damages and come in contact with the skin, wash immediately under running water for more than 15 minutes and consult a physician.
- (2) LCD may have uneven brightness depending on the contents displayed. Please note that this is not a malfunction.
- (3) LCD elements may have spots (black spots/ bright spots). This is a characteristic of the LCD and not a malfunction.
- (4) When screen is viewed outside the viewing angle, the color displayed may appear to change. This is a basic characteristic of the LCD and not a malfunction.
- (5) When the same screen is displayed for a certain long period of time, the image may remain as an afterimage. This is a basic characteristic of the LCD.  
In order to avoid afterimages, use a screensaver or other similar functions to periodically change the display and avoid displaying the same image for a long period of time.

## 10-4 Precautions for Resistive Touchscreen

- (1) Applications that require to press the same point on the touchscreen for a long time may cause malfunction due to the structure of the touchscreen.  
The touchscreen is made of glass. Glass is easily damaged when scratched.  
Please handle the touchscreen so that glass does not come in contact with other glass or hard objects.
- (2) The touchscreen is made of glass. Glass can easily break if scratched.  
Please handle the touchscreen so that glass does not come in contact with other glass or hard objects.
- (3) Due to the characteristics of the touchscreen, area slightly outside the display area may be detected as the coordinates of the edge of the touchscreen. Please design your application with this in mind.
- (4) The coordinates of the touchscreen may shift over time or depending on the environment in which it is used. If the touchscreen coordinates get misaligned, please conduct calibration for coordinate correction.
- (5) Handle the edge of the glass with care as it may cause injuries.



### **10-5 Precautions for Static Electricity**

- (1) Static Electricity may cause damages. Please take sufficient measurements when handling.
- (2) Any personal handling the product should take measurements. Wearing grounding bands is recommended.

### **10-6 Operating Precautions**

- (1) When used outside the specification standards, it may significantly affect product quality and service life, such as degradation of display quality and generation of air bubbles. Please be sure to use within the specifications.

### **10-7 Storing Precautions**

- (1) When storing the module, please avoid areas of high temperature and humidity. Especially when storing for a long period of time, make sure to store in a place that is not be exposed to direct sunlight and/or fluorescent lighting.
- (2) Please store the module in a condition where it is not subject to excessive load.

### **10-8 Handling Precautions**

- (1) Do not leave the product in an environment with high temperature for a prolong period. Make sure to avoid high humidity especially when the temperature is above 40°C. Failing to do so may cause polarizing plate deterioration, peeling, and/or bubbles to form.
- (2) If the surface of the polarizing plate becomes dirty, wipe it lightly with a soft material such as cotton cloth moistened with a small amount of ethyl alcohol.
- (3) Make sure to wipe off immediately any form of liquids to avoid deformation, discoloration or fading of the polarizing plate.
- (4) Condensation on the polarizing plate during testing is prohibited to prevent staining, discoloration, or spots to form on the plate.
- (5) Disassembling and/or changing the volume of the module is prohibited. Doing so may cause malfunction and failure to perform correctly.
- (6) This product is intended for use in general electronic equipment and is not intended for use in special environments such as corrosive gas atmosphere. If use in a special environment is anticipated, please evaluate the product thoroughly or take precautions not to expose the LCD to corrosive gases, etc.
- (7) This product is intended for use in standard applications (office equipment, industrial, communication, and household equipment, etc.). Do not use the products for special applications that require extremely high reliability (e.g., aerospace, nuclear power control, medical applications for life support, etc.) or where malfunctions or failures may directly cause injuries to the human body.
- (8) Do not rub or press the product with hard or sharp objects.
- (9) Keep away from flames/fire.
- (10) Avoid wiping the product with excessive pressure.
- (11) Avoid locally rubbing the product with strong pressure. It may cause damage to the function of the touchscreen.
- (12) When operating the product, please avoid striking it with a hard object.
- (13) Do not forcibly fold or bend the product.

- (14) When storing the product, use the packing box and keep the product within the specified storage temperature and humidity and in an environment where it is free of excessive pressure and loads.
- (15) Avoid using and storing the product where it can be exposed to or can come in contact with liquids, organic solvents, and acidic atmosphere.
- (16) Avoid using the product in direct sunlight.
- (17) Do not pull off or disassemble the product.
- (18) When handling the product, hold the main unit and not the touchscreen FPC (tail).
- (19) EMC (EMS, EMI) evaluation is not conducted at shipment. Please conduct overall evaluation and confirmation after the product has been installed in your equipment.

## **11 Warranty**

The warranty period is limited to 12 months (1 year) from the date of shipment. Any defects that occur upon normal use under conditions specified herein will be repaired (factory repair) free of charge. (Warranty for any repair needed to the same repaired part of the same product is three months.)

You will be liable for all repair fees even within the warranty period for any conditions listed below.

- (1) Any malfunctions, defects, and/or damages that occurred during transport, transfer, or mishandling by the user after delivery.
- (2) Any malfunctions, defects, and/or damages caused by natural or man-made disaster.
- (3) If the product is used under any condition, environment, or method other than those specified in the specifications, catalogs, manuals, notes, and/or other documents.
- (4) Any malfunctions, defects, and/or damages caused by connected equipment and/or usage of inappropriate consumables and media.
- (5) If the product is repaired, remodeled, modified, or disassembled by a party other than DMC Co., Ltd, or if a serial number label cannot be verified.
- (6) Any failure, damage, or malfunction is deemed to be caused on your behalf.

This warranty covers only the product itself. Any damages, on-site repairs and replacement driven by the failure of the product will be decided upon discussion by both parties as necessary. This product is structurally not repairable. All damaged parts are subject for replacement and freight will be charged.

## **12 Production Discontinuance**

In the event of production discontinuance, an announcement will be made six months prior to the last possible order reception date.

## 13 Other

For comments or queries, feel free to contact us.

North South America area

[technical-global@dush.co.jp](mailto:technical-global@dush.co.jp)

Asia Pacific area

[technical-global-asia@dush.co.jp](mailto:technical-global-asia@dush.co.jp)

Europe, Middle East, Africa area

[technical-global-eu@dush.co.jp](mailto:technical-global-eu@dush.co.jp)

FAQ

<https://www.dush.co.jp/english/support/faq/>

---

3rd Edition, December 2023

DMC Co., Ltd.

Business hours: 9:00a.m.~5:00p.m. (Central Time)

URL: <https://www.dush.co.jp/english/>

This document is protected by copyright law. Photocopying, duplicating, reproducing, and modifying of this product or document in part or by whole is prohibited.

Copyright(C) 2023 DMC Co., Ltd. All Rights Reserved

寸法許容差 呼び寸法 Nominal Dimensions	TOLERANCE
L ≤ 3	±0.4
3 < L ≤ 6	±0.48
6 < L ≤ 10	±0.58
10 < L ≤ 18	±0.7
18 < L ≤ 30	±0.84
30 < L ≤ 50	±1.0
50 < L ≤ 80	±1.2
80 < L ≤ 120	±1.4
120 < L ≤ 180	±1.6
180 < L ≤ 250	±1.85
250 < L ≤ 315	±2.1
315 < L ≤ 400	±2.3
400 < L ≤ 500	±2.5

SYM	改訂日 DATE	改訂内容 DESCRIPTION	ページ PAGE	担当 DESIGNED
	2023.02.27	新規図面登録	—	S. Takada

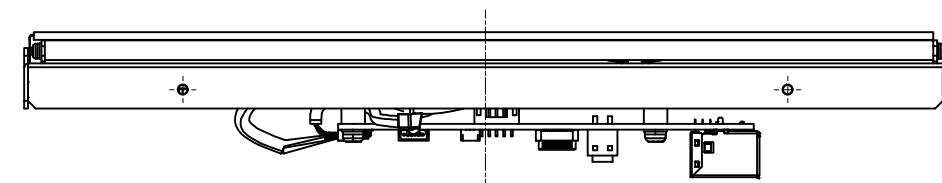
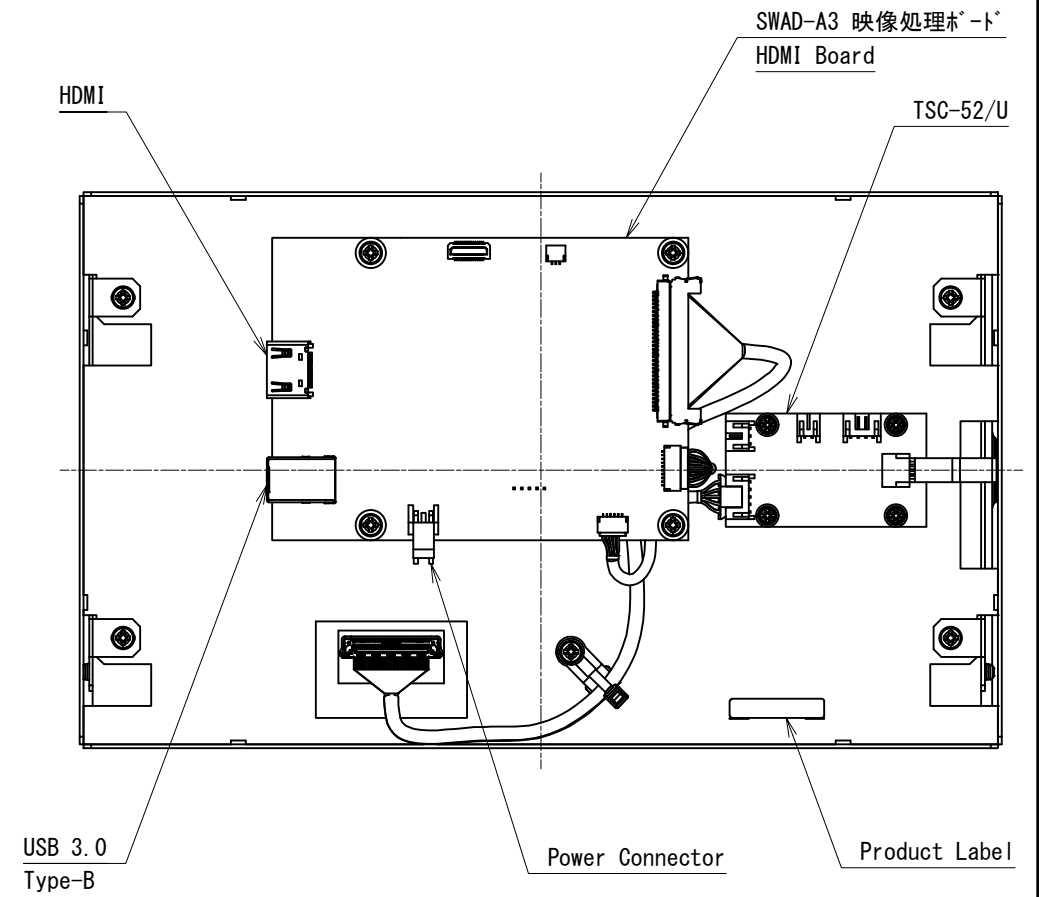
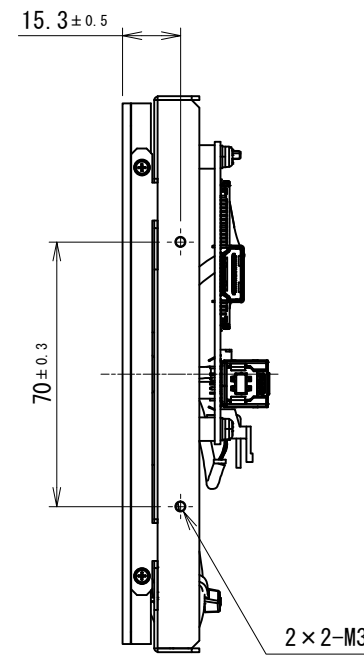
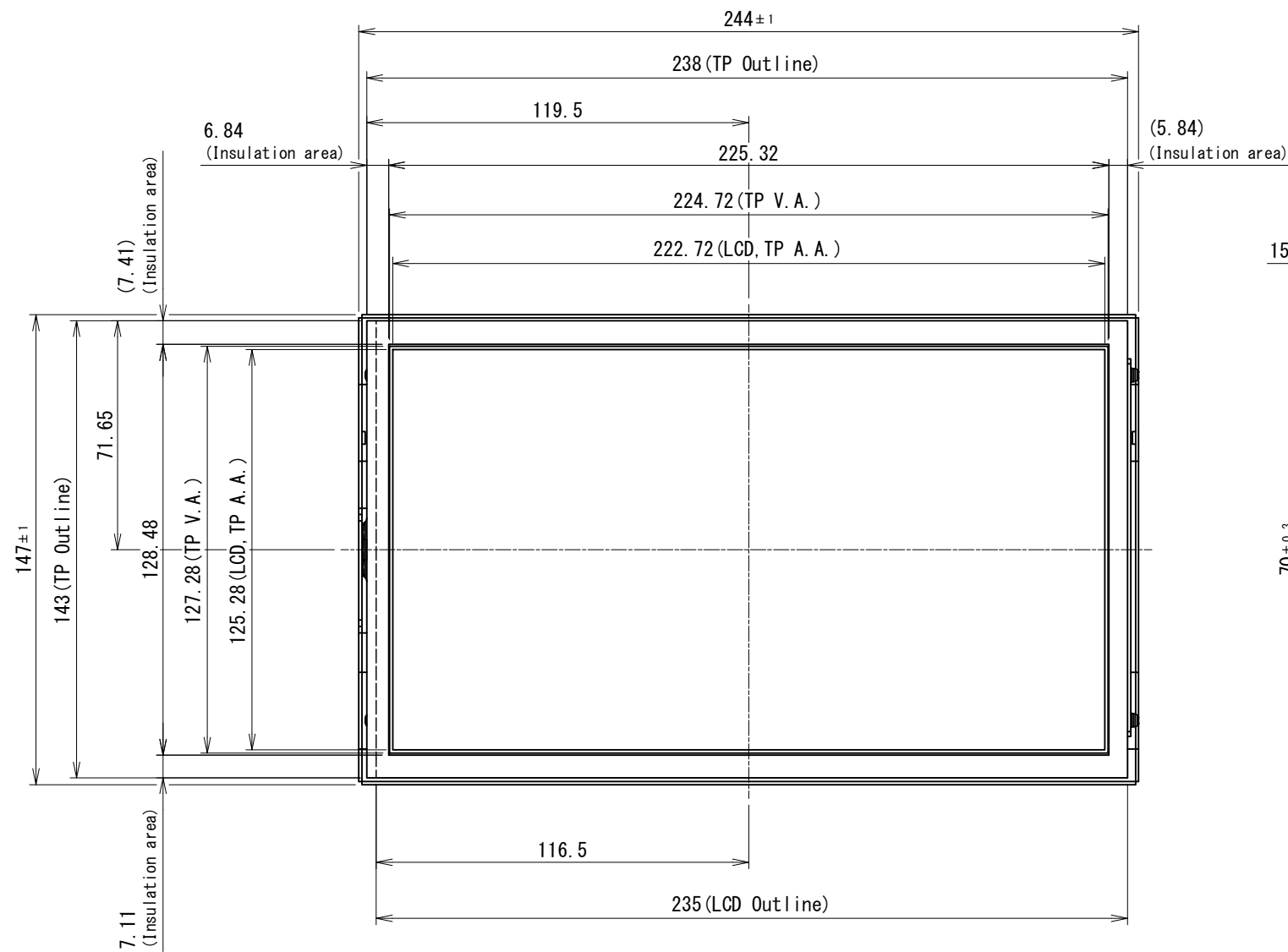
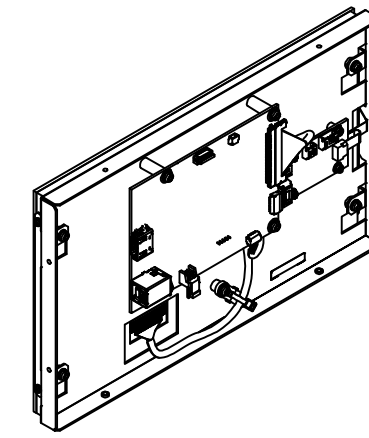
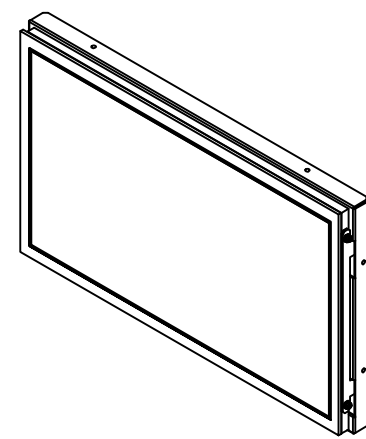
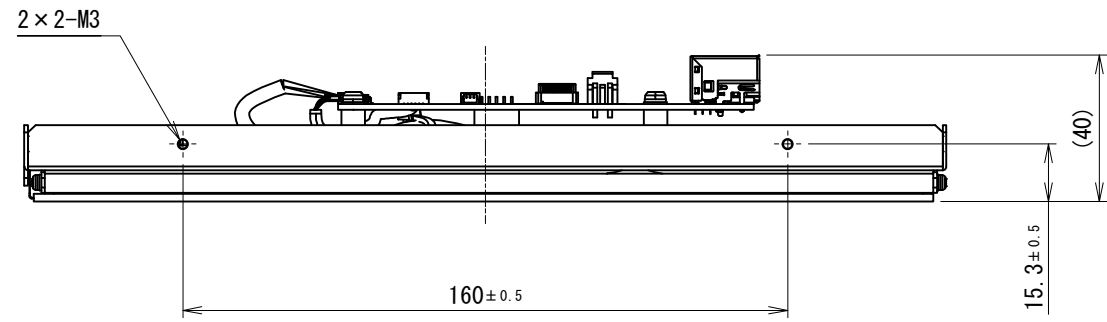

NOTES  
1. 指示なき寸法公差は寸法公差表の通りとする。  
Tolerance shall be of dimensional tolerance table unless specified otherwise.

製図日 ISSUED	2023.02.27	部署 SECTION	Technical Dept.	尺度 SCALE	CAD登録名 CAD FILE NAME	OUTLINE_TK-BRA101WS-01A3	RoHS対応品 RoHS compliant
承認 APPROVED		検図 CHECKED		1:2	製品名 MODEL	TK-BRA101WS-01A3	
		製図 DRAWN	S. Takada	単位 UNIT	図名 TITLE	OUTLINE	ページ PAGE
T. Okada	S. Yoshimoto		S. Takada	mm			1 / 1
DMC Co., Ltd.			A3	図番 DWG No.	SM3-002366-10		

## Resistive Touch Screen Mounting Guidance

Jan 24, 2023

DocNo.DET-M0003A

**\*Refer to the suggested structure and mounting precautions in this document at mounting the touch screens. Appropriate structure differs according to touch screen size, LCD, chassis design, usage environment and so on. Please conduct the evaluation with actual products at the trial stage, and confirm that your structure is appropriate prior to fixing the structure design.**

### ① Suggested Touch Screen Mounting Structure

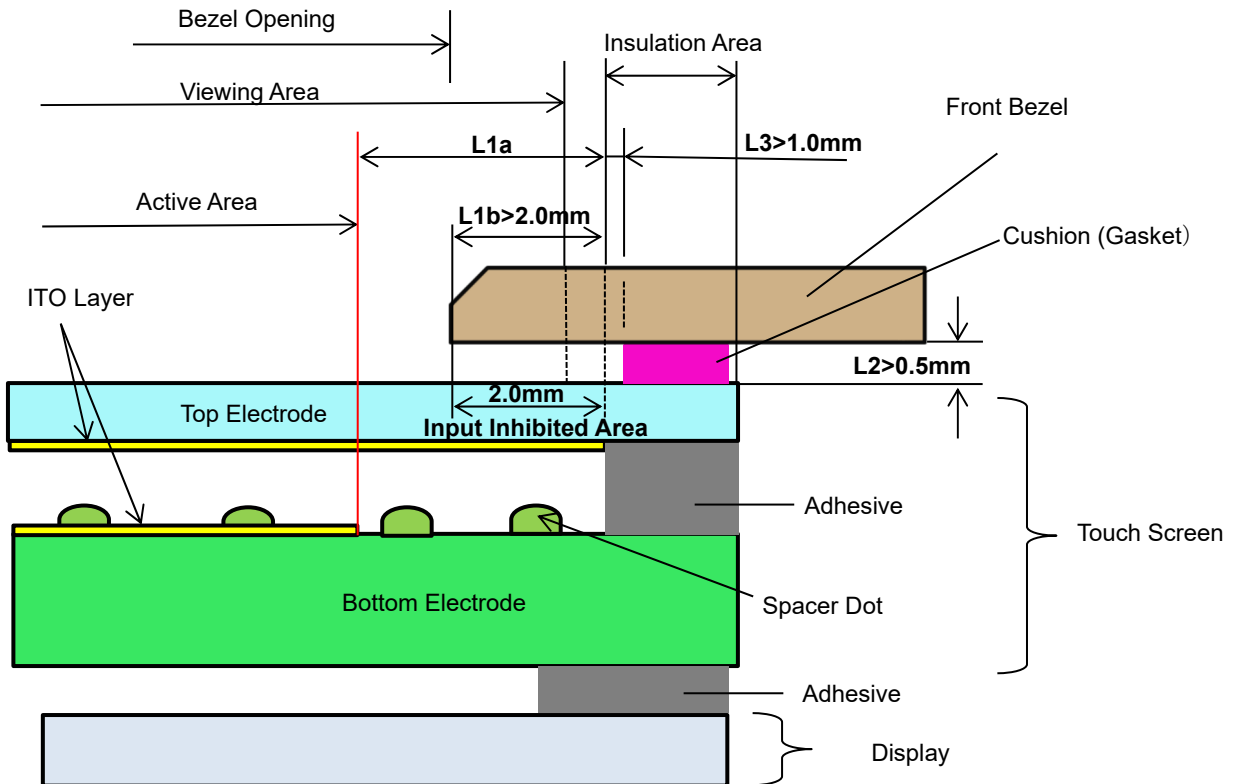

Fig.1

## ② Mounting Precautions

### a. Bezel Edge (Fig.1&2)

Bezel edge is suggested to be positioned in the area between active area and insulation area (L1a). If the bezel edge overlaps the active area, it may cause a false input when the bezel is pressed.

Input Inhibited Area (refer to the section d.) is structurally weak against pressure. If the distance between active area and insulation area (L1a) is 2.0mm or longer, the bezel edge (L1b) is recommended to be longer than 2.0mm so that the Input Inhibited Area will be protected by the bezel.

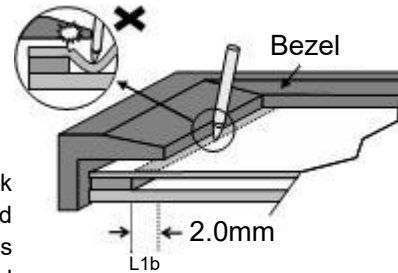

Fig.2

### b. Gap between Bezel and Touch Screen (Fig.1&3)

A gap between bottom of the bezel and the touch screen surface (L2) needs to be longer than 0.5mm. Otherwise, the bezel edge may cause false input when the bezel is pressed.

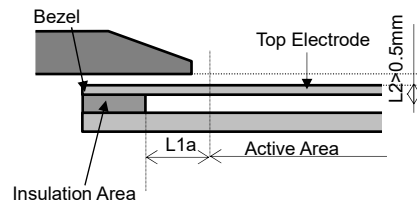

Fig.3

### c. Area between Active Area and Insulation Area (Fig.1&3)

If the area between the active area and insulation area (L1a) is pressed, false input may be caused. Do not touch this area. (Fig.3)

### d. Input Inhibited Area (Fig.1&4)

2.0mm from the edge of the insulation area toward the viewing area (Input Inhibited Area) is structurally weak against pressure., especially by a pen. If the top electrode is a film, and this area is touched by a pen, the film may get stretched and the touch screen gets broken, Do not touch on this area directly.

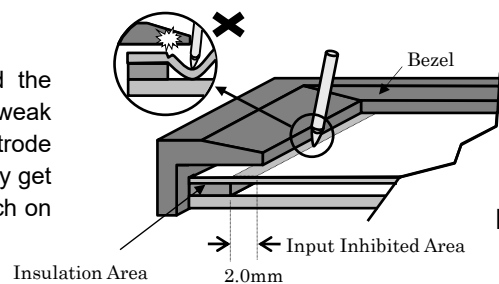

Fig.4

### e. Cushion (Gasket) (Fig1&5)

If a cushion is used between the bezel and the touch screen surface, the cushion must be free enough to absorb the expansion and contraction difference between the bezel and the touch screen surface. If the cushion is squashed too hard, the expansion and contraction difference may cause the distortion to the touch screen surface.

The cushion must be positioned more than 1.0mm (L3) outward from an inside of the insulation area. (Refer to Fig.5 & the drawing)

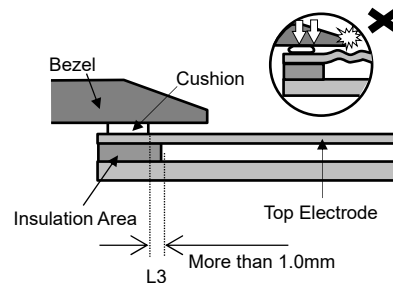

Fig.5

**f. Tolerance (Fig.6)**

There is a tolerance of 0.2 to 0.3mm for the dimensions of the touch screen and the FPC connector cable. A gap must be made to absorb the tolerance in the case and the connector.

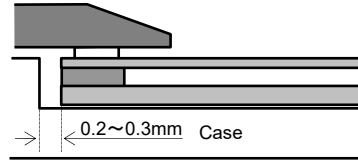

Fig.6

**g. FPC Connector Cable (Fig.7)**

The FPC connector cable must not be forcibly stressed or bent too hard to avoid the conduction in the insulated area and wire breaking.

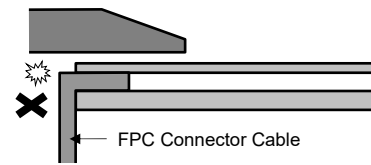

Fig.7

**h. Mounting Touch Screen (Fig.8)**

Touch screen must be held from the bottom, such as the structure gluing the touch screen onto the display. If the touch screen is glued to the bezel, the adhesion between the top and bottom electrode is stressed and may come off.

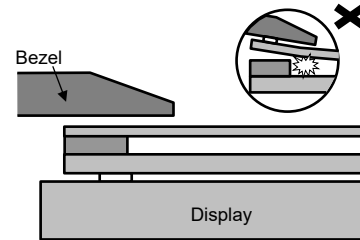

Fig.8

**i. Air Vent (Fig.9)**

Some touch screens have the air vent to equalize the inside air pressure to the outside one. The air vent must not be covered, and liquid contact must be avoided as the liquid may be absorbed if the liquid is accumulated near the air vent. The top electrode must not be swelled by the air pressure from inside of the case.

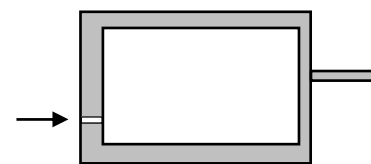
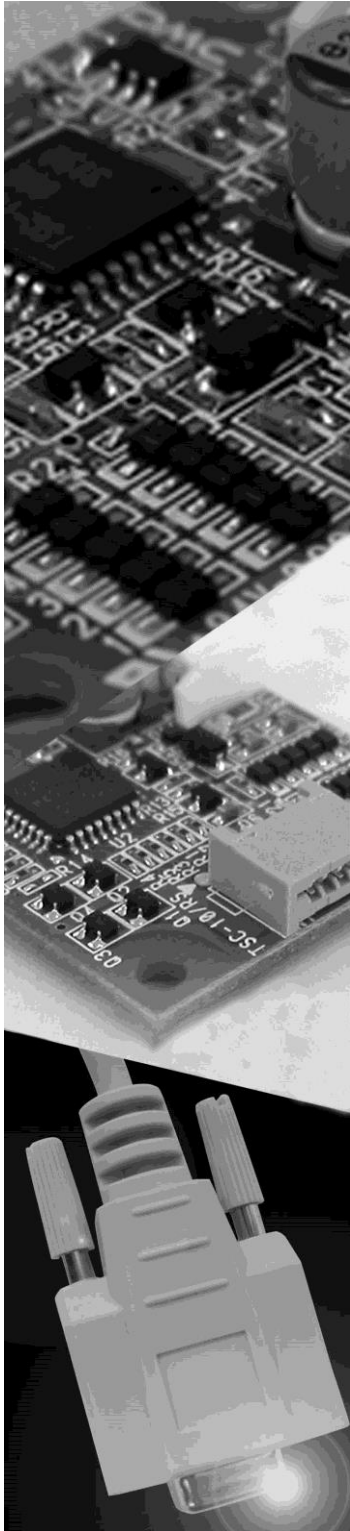

Fig.9



 **DMC Co., Ltd.**  
*Interface with Touch*

## **Analog Resistive Touch Screen Controller Board with Gesture Function TSC-52/U User's Guide**



## Table of Contents

<b>1. Product Overview</b> .....	<b>2</b>
1.1. Products Applicable.....	2
1.2. Overview .....	2
1.3. Peripheral Composition Overview .....	3
1.4. Supported Sizes of Touch Screens .....	4
1.5. Gesture function.....	4
<b>2. Specifications</b> .....	<b>5</b>
<b>3. Connector</b> .....	<b>7</b>
3.1. Explanation of a connector terminal .....	7
3.2. The mounted connector.....	7
<b>4. Interface type</b> .....	<b>8</b>
4.1. Serial mode .....	8
4.2. USB mode.....	8
<b>5. Packing Specification</b> .....	<b>9</b>
5.1. Outline.....	9
5.2. Packing material.....	9
5.3. Outer case and lot label.....	9
5.4. Product name label .....	10
<b>6. Changes &amp; Improvements</b> .....	<b>11</b>
6.1. Version History .....	11
<b>7. Warranty</b> .....	<b>12</b>
7.1. Warranty Period .....	12
7.2. Warranty Target .....	12
7.3. Warranty Exceptions .....	12
<b>8. Precautions for Use</b> .....	<b>13</b>
8.1. General Handling .....	13
8.2. Others.....	13

## Dimensional Drawing

## **1. Product Overview**

### **1.1. Products Applicable**

This specification is applicable to TSC-52/U.

### **1.2. Overview**

This is the IC to be used to realize gesture functions with 2-finger such as flick, pinch-in/pinch-out, rotation along with recommended circuit for 4-wire resistive Touch Screen.

This is the controller IC to transform analog signals from 4-wire Touch Screen into coordinates data of 10-bit resolution using AD conversion and then send them to host computer. Filtering processing function in the IC during detecting coordinates data enables to obtain stable coordinates data. Also using compensation function on the host computer side can compensate the coordinate deviation between an input point on Touch Screen and a point of cursor indication and make them match to the one point.

- § TSC-52/U      TSC-52/U dispenses a need to newly design the peripheral circuits, and can easily be used by connecting to the touch screen and the host. Using the driver software enables the mouse emulation on various operation systems and dispenses the need to newly design the controller software.
- In addition, the correction data can be saved in the IC on the board with the built-in EEPROM.

TSC-52/U is lead-free and compliant with RoHS.

### 1.3. Peripheral Composition Overview

A resistive touch screen is operated by resistance sensitive system between two layers such as film or glass. Two pieces of transparent materials with conductive coating are placed in the same direction as two electrodes face each other. The touch screen is activated when these transparent conductive layers are pressed to contact each other with a finger or a pen. The one of these conductive layers functions as an X-coordinates electric circuits and the other as a Y-coordinates circuits. To measure the X-coordinates TSC-52/U supplies voltage,  $V_{cc}$  to the one of X-coordinates electrodes with GND to the other. When the touch screen is pressed under this environment the voltage of the X-coordinates resistance is detected by the Y-coordinates electrode ( $A_{in}$ ) at the input point ( $x1$ ), where the X-Y coordinate resistance layers make contact. The detected voltage in supply side is higher than the GND side, which means ' $A_{in}$ '= $V_{cc}$  at the point 'E' and ' $A_{in}$ '= $0(*1)$  at the point 'A'. TSC-52/U calculates coordinates data starting from A/D conversion of the ' $A_{in}$ ' voltage. The Y-coordinates is measured in the same way. By repeating this process alternately, coordinate value at the input point is determined.

(\*1) Excluding the loss in the controller circuits and touch screen. Actual detected voltage should be lower than ' $V_{cc} - GND$ ' because of loss happened in the circuitry.

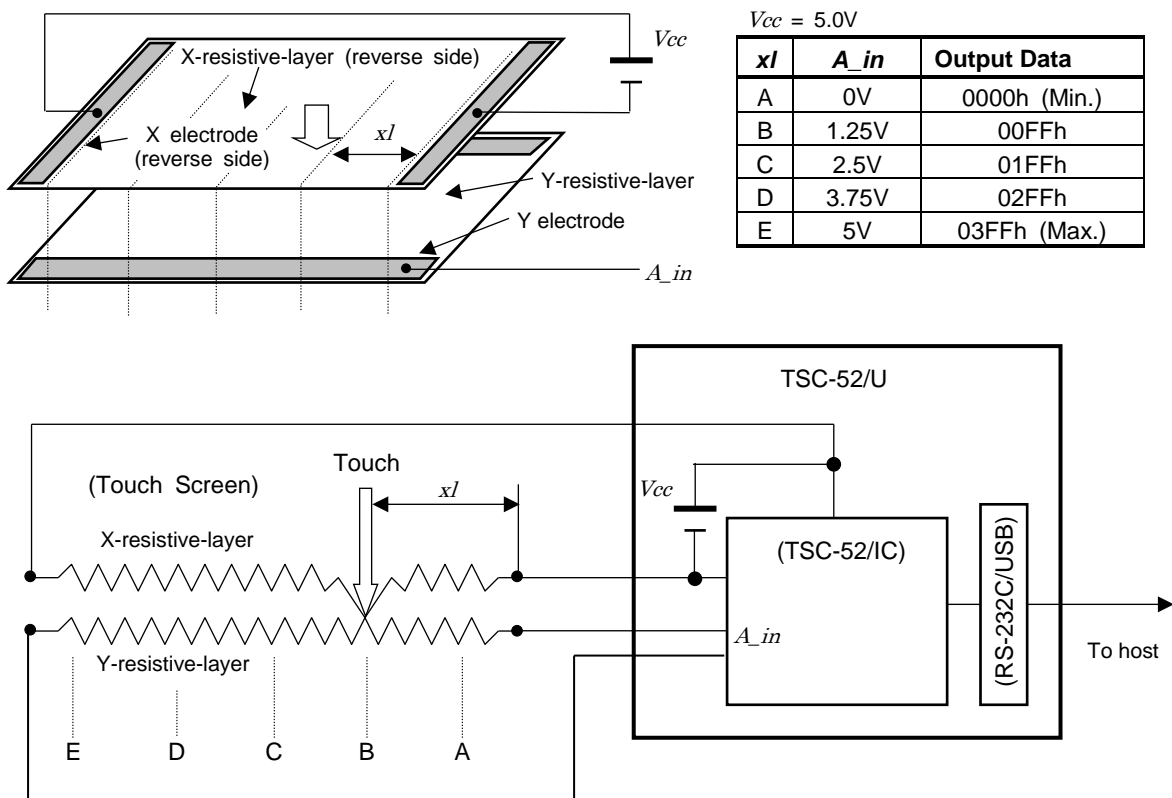

### 1.4. Supported Sizes of Touch Screens

The supported sizes of touch screen is from 4.3inch Wide to 21.5inch Wide in DMC's 4-wire resistive touch screen lineups. (LST touch screen series is recommended)

\*Please note that pin pitch of LST 4.3inch model is different from other LST models .  
([TSC-52/U] is for 1.25mm pin pitch while pin pitch of LST 4.3inch model is 1.00mm)  
For LST 4.3inch model, please use another controller, [TSC-52/U-F].

### 1.5. Gesture function

#### (1) Pinch-in/Pinch-out

Pinch-out is defined as the motion that when 2 points are input, the distance between them moves bigger. While Pinch-in is defined as the motion that when 2 points are input, the distance between them moves narrower. There are two case in Pinch-in/Pinch-out as shown below.

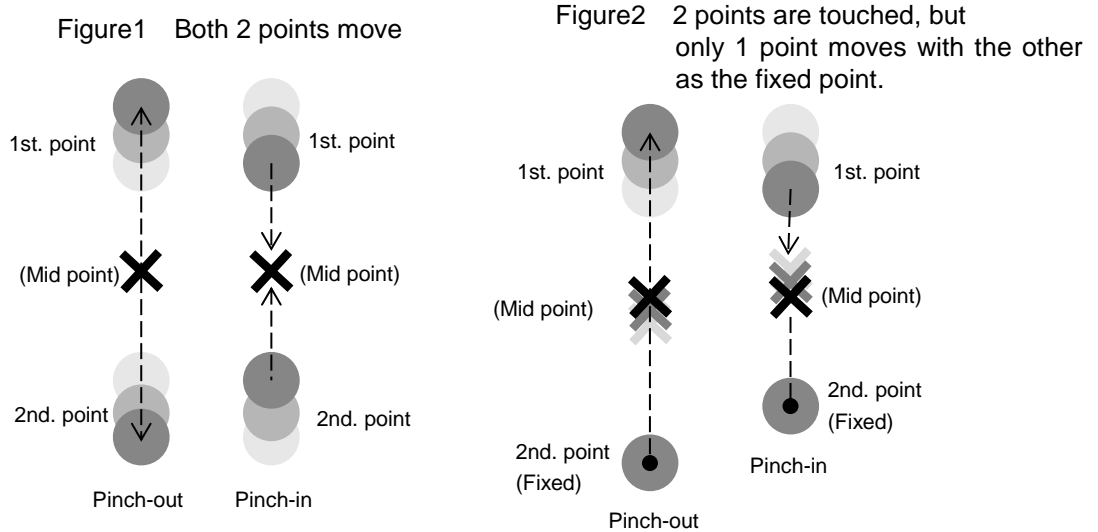

#### (2) Rotation

Rotation is defined as the motion that when 2 points are input, the both 2 points rotate clockwise or counter-clockwise with the mid point as center, and one point rotates with the other fixed as center.

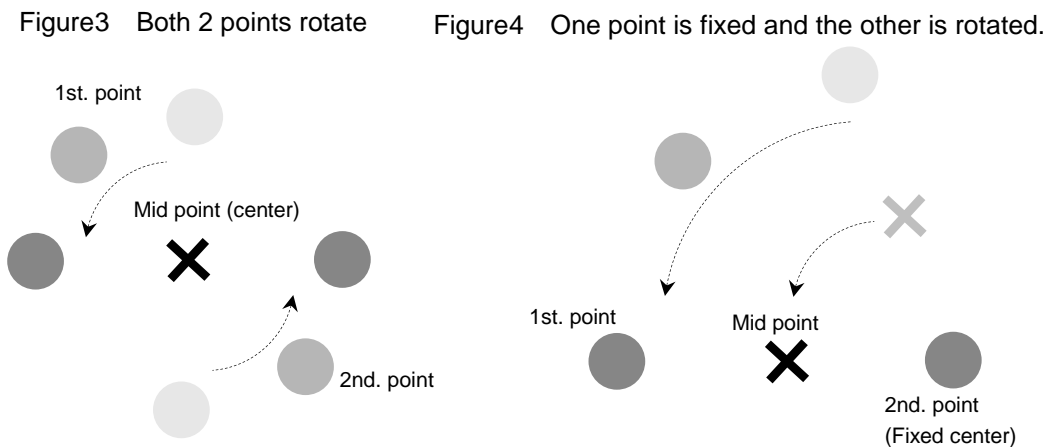

## 2. Specifications

### General Specifications

Item		Rating	Remarks
Operating Temp.	Serial/USB	-40°C to +85°C	No dew condensation
Storing Temp.	Serial/USB	-40°C to +85°C	No dew condensation
Supply Voltage		DC 5.0V ± 5[%]	
Consumption Current		55mA (TYP)	In USB mode, Vin=5.0V, one point touch input.
Correspondence (Serial)	Format	Asynchronous Serial	Fixed value
	Transfer Rate	9600bps	
	Data Format	8bit	
	Stop Bit	1bit	
	Parity	None	
Correspondence (USB)	Spec	USB Specification 2.0 Full Speed	
	Transfer Mode	Interrupt transfer (coordinate)	
	Device class	HID	
Frequency		16MHz	16MHz fixed
Dimension		30 x 53 mm	
Max height of components		4.8 mm	

Performance Specifications

Description	Rating	Note
Coordinate Output Rate (point/sec)	150p/s	
Coordinate Resolution	10bit (1024 x 1024)	The value will be lower in the active area of the touch screen
Linearity Error	±3 LSB	
Input Response Time	10ms (TYP)	
2-point Input Resolution	Min. 2-point input-able distance: 7mm typ. After gesture calibration : 4mm typ.	with LST-121B080A (12.1in) *Refer to the graph shown below

Note : This product does not guarantee position accuracy in two-point(two-finger) touching since it is a touch screen controller exclusively designed for realizing gesture functions with two-finger touch.

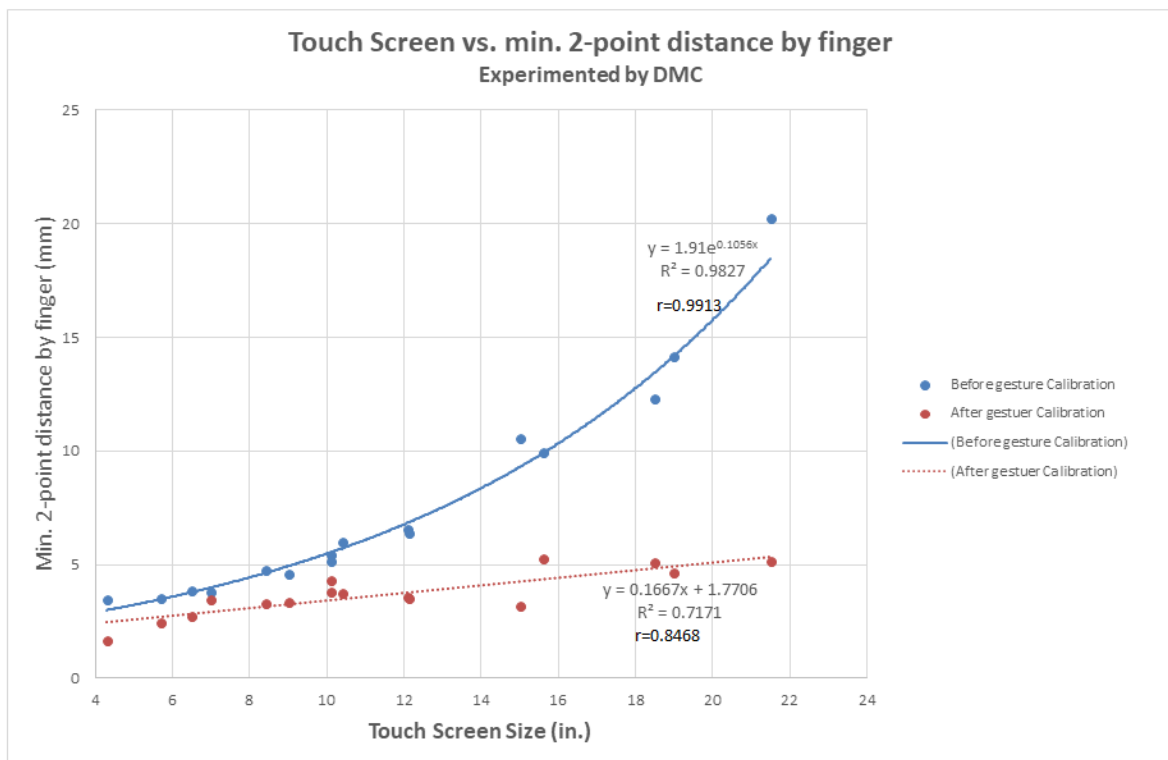

### 3. Connector

#### 3.1. Explanation of a connector terminal

CN	Terminal	Name	Function
CN1	1	Vin	Power Input
	2	GND	GND
CN2	1	Vbus	USB Vbus
	2	D-	USB D-
	3	D+	USB D+
	4	GND	USB GND
	5	Shield	USB FG
CN3	1	Dout	RS-232C Data Output
	2	Din	RS-232C Data Input
	3	GND	RS-232C GND
CN5	1	XL	Touch screen Input XL.
	2	YU	Touch screen Input YU.
	3	XR	Touch screen Input XR.
	4	YD	Touch screen Input YD.
CN8	1	I2C0_SDA	Unused
	2	I2C0_SCL	Unused
	3	TEST1	Unused
	4	GND	Unused

#### 3.2. The mounted connector

CN	P/N	Manufacturer
CN1	S2B-PH-K-S	J.S.T. Mfg Co., Ltd
CN2	S5B-PH-K-S	J.S.T. Mfg Co., Ltd
CN3	S3B-PH-K-S	J.S.T. Mfg Co., Ltd
CN5	IMSA-9604S-04F	IRISO ELECTRONICS Co., Ltd
CN8	S2B-PH-K-S	J.S.T. Mfg Co., Ltd

## 4. Interface type

TSC-52/U has serial and USB interface type. You choose either type. You cannot use both these at the same time.

(Notice) In the state that connected a serial and a USB cable to a computer, please do not start power on of TSC-52/U and computer. Because it may cause malfunction.

### 4.1. Serial mode

In serial mode, please use CN3 for connecting to host computer, and CN1 for power supply.

#### Specifications

Transmission format: Asynchronous serial

Transfer rate: 9600bps

Data format: 8 bit

Stop bit: 1 bit

Parity: None

### 4.2. USB mode

In USB mode, please use CN2 for connecting to host computer.

#### Specifications

Transmission spec: USB Specification 2.0 Full Speed

Transfer mode: Interrupt transfer (Coordinate)

Device class: HID



## 5. Packing Specification

### 5.1. Outline

TSC-52/U is wrapped up in the air packing of the prevention of static protection type and puts it in a packing box.

### 5.2. Packing material

Outer case: 75 x 55 x 15 mm, clay coated newsback board

Cushioning: 120 x 70 mm, air packing, static protection

### 5.3. Outer case and lot label

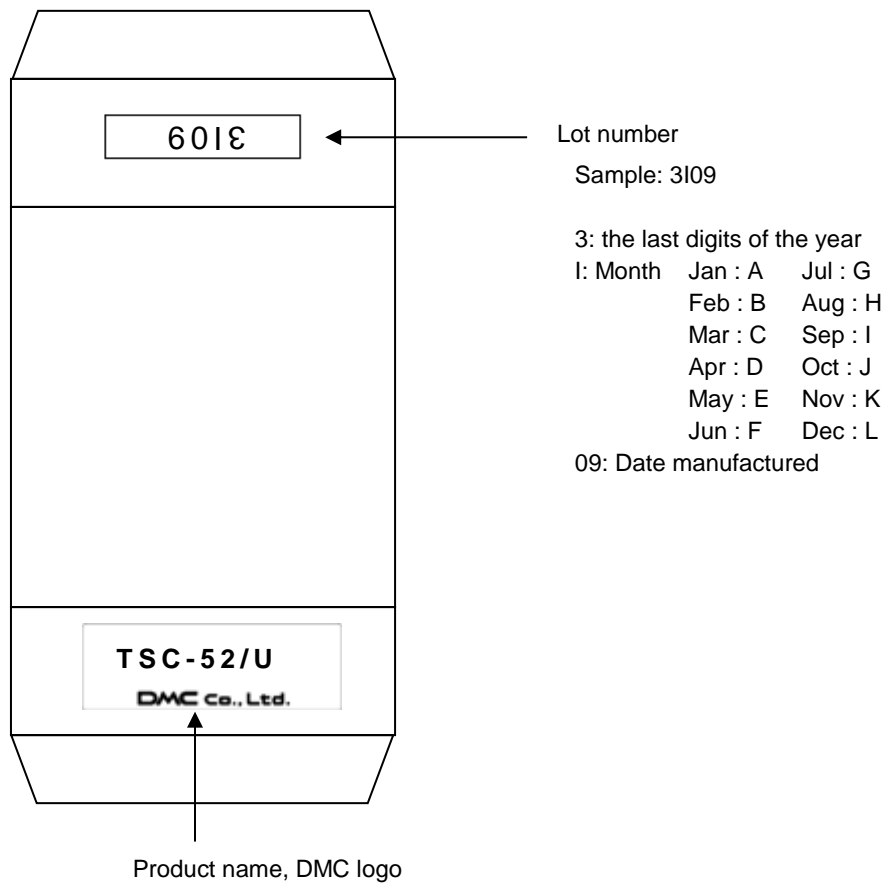

### 5.4. Product name label

Backside of board  
(Sample)

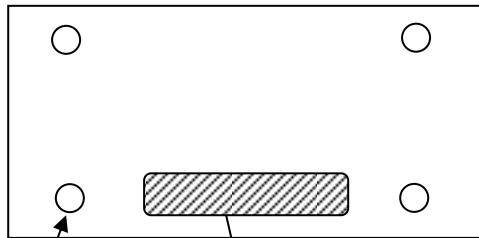

Screw Hole

Product Name Label

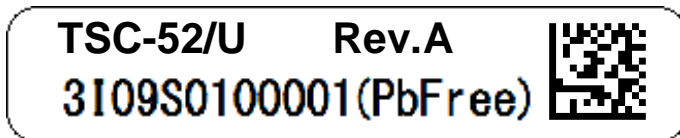

TSC-52/U: Product name  
Lot#: 3I09S0100001

Definitions of the lot number  
3I09

3: the last digits of the year

I: Month Jan : A Jul : G

Feb : B Aug : H

Mar : C Sep : I

Apr : D Oct : J

May : E Nov : K

Jun : F Dec : L

09: Date manufactured

S01: Control number for DMC use  
00001: Serial number (5 digits)

Rev: Revision information

(PbFree): lead free

Data Matrix: lot number [3I09S0100001] can be read with a barcode reader. (Product name and revision information are not included.)

## 6. Changes & Improvements

### 6.1. Version History

Ver.1.0 (October 28, 2020)

First edition release

Ver.1.1 (November 20, 2020)

2. Specifications :Performance Specifications “Note” is added.

Ver. 2.0 (June 16, 2021)

1.2. Overview: Added the description that EEPROM is built in TSC-52 / U.

2. Specifications: Revised the Operating and Storing Temp of General Specifications.  
(Lower limit temp.)

5.4. Product name label: Corrected the QR code to Data Matrix.

## **7. Warranty**

### **7.1. Warranty Period**

- § The warranty period is limited to 1 year from the date of shipping. The warranty for the initial deflection such as appearance deflection is limited to 1 month.
- § Any defected parts under proper use will be examined by the supplier and replaced by the new parts if the deflection is considered to be caused by the supplier.
- § The replacement is subject to be included in the next lot.

### **7.2. Warranty Target**

- § The warranty only covers the product itself and does not cover any damage to others caused by using this product. Onsite repair or replacement is not supported.
- § We will do our best for delivery problem and product deflections, but the warranty for the production line is not covered.

### **7.3. Warranty Exceptions**

Following conditions are not covered with the warranty and subject to charge.

- § Any malfunctions and damages during transportation and transfer by the user.
- § Any malfunctions and damages caused by a natural disaster or a fire.
- § Any malfunctions and damages caused by static electricity
- § Any malfunctions and damages caused by the failure of the associated equipment.
- § If the product is remodeled, disassembled or repaired by the user.
- § If the product is glued onto the equipment and uninstalled.
- § Any malfunctions and damages caused by an improper usage and handling against the specifications and notes.

## 8. Precautions for Use

### 8.1. General Handling

- § Keep the product away from any conductive objects while in use.
- § Do not touch the conductive part of the product to avoid being damaged by the electrostatic discharge.  
Follow the proper procedure for handling.
- § Keep the product in the proper storing environment and avoid any load to the product.
- § Do not use or store the product in the severe condition like following:
  - Wet environment or a condition where the product is likely to get wet.
  - Where dew condensation is likely to occur.
  - Near solvent or acid.
- § Do not take apart or alter the product.

### 8.2. Others

- § The contents of this document are subject to change without notice.
- § The manufacturer or sales representatives will not be liable for any damages or loss arising from use of this product.
- § This product is intended for use in standard applications (computers, office automation, and other office equipment, industrial, communications, and measurement equipment, personal and household devices, etc.) Please avoid using this product for special applications where failure or abnormal operation may directly affect human lives, or cause physical injury or property damage, or where extremely high levels of reliability are required (such as aerospace systems, vehicle operating control, atomic energy controls, medical devices for life support, etc.).
- § Any semiconductor devices have inherently a certain rate of failure. The user must protect against injury, damage, or loss from such failures by incorporating safety design measures into the user's facility and equipment.

TSC-52/U User's Guide  
Rev. 2.0 June 16, 2021  
©2021 DMC Co., Ltd.

This document can be freely distributed, but any alternation to this document is prohibited.

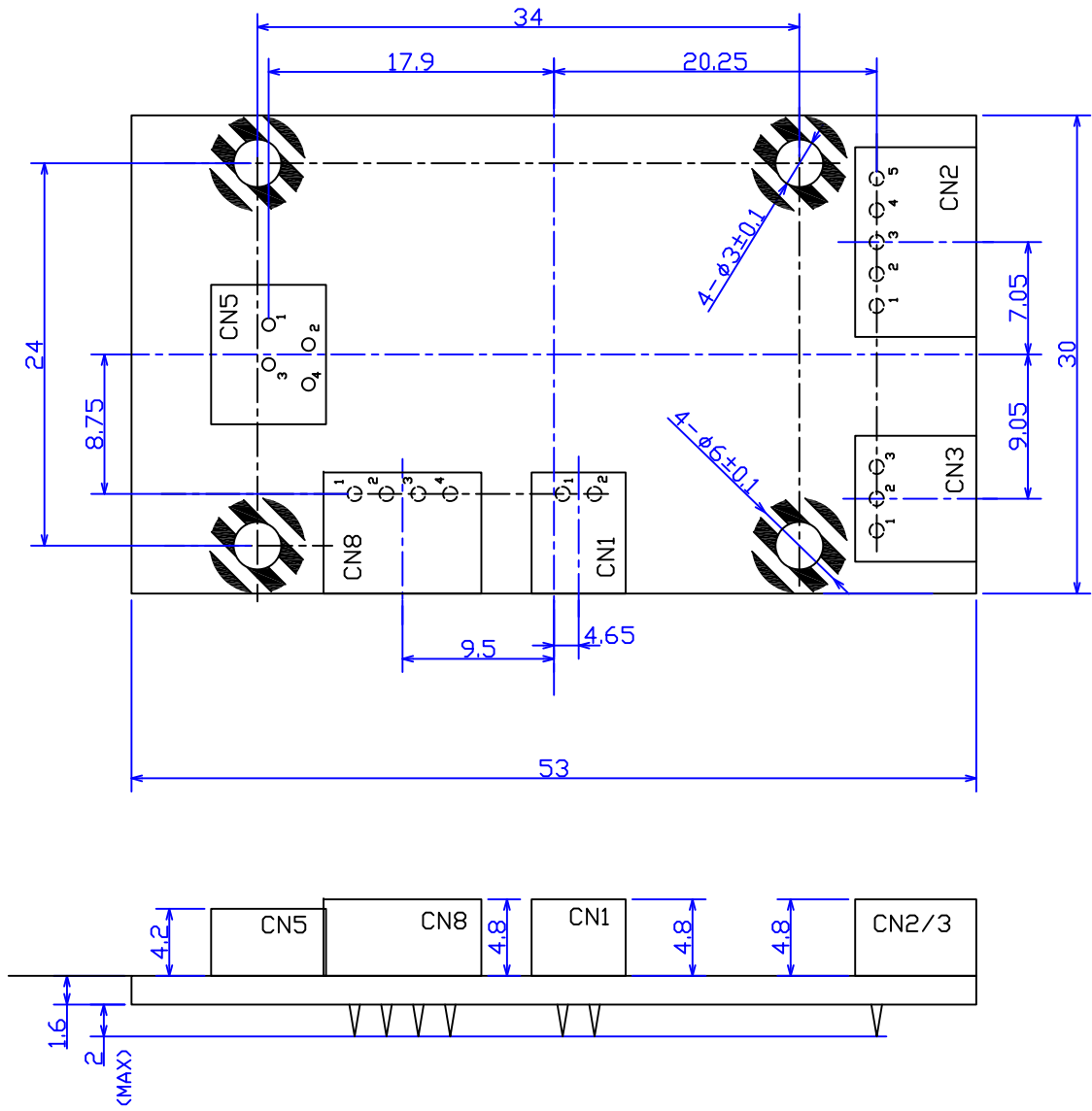

※Tolerance:  $\pm 0.3\text{mm}$  except for hole diameter  
 ※Material: FR-4  
 ※Mass: 8g (Typ.)  
 ※Unit: mm

Date	P/N
October 28, 2020	TSC-52/U
Name	
Dimensional Drawing	Rev.1.0
DMC Co., Ltd.	



# Appearance Inspection Standard ( 1 )

## 1.1 Inspection condition

Inspection Distance :  $35 \pm 5$  cm

View Angle : Inspection under non-operating condition :  $\pm 30^\circ$

Ambient Illumination : 500~2000 lux

Inspection time : 3~5 seconds

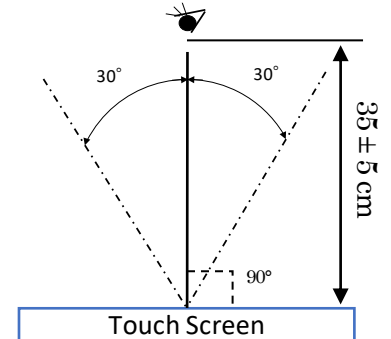

## 1.2 Scratch, dust (W = width, L = length, D = average diameter = (longest + shortest) /2))

Total defects on each panel.

- 【 14 inches < Size  $\leq$  22 inches 】 Within 10 pcs / panel
- 【 10 inches < Size  $\leq$  14 inches 】 Within 7 pcs / panel
- 【 Size  $\leq$  10 inches 】 Within 5 pcs / panel

Item	Width(mm)	Length(mm)	Acceptable Numbers
<b>Linear(Scratch/Dust)</b> Over 0.1mm in diameter refer to the Circular.	$0.05 < W \leq 0.1$	$L \leq 4$	1pcs in $\phi 30$ mm
	$0.03 < W \leq 0.05$	$L \leq 10$	2pcs in $\phi 20$ mm
	$W \leq 0.03$	$L \leq 20$	Acceptable
<b>Circular(Scratch/Dust)</b>	$0.3 < D \leq 0.4$		1pcs in viewing area *1
	$0.2 < D \leq 0.3$		2pcs in $\phi 30$ mm
	$D \leq 0.2$		Acceptable

Applied only in the Viewing Area.

Scratches or dusts in the outside of the Viewing Area are acceptable unless the electrical characteristics are affected.

\*1 Applied to 14 inches or larger panel.

- Acceptable if not noticeable on a black mat.

Product	LCD Modules with Resistive Touchscreen	Document No.	22G4GX-00001E-0
---------	--	--------------	-----------------



## Appearance Inspection Standard ( 2 )

### 1.3 Chip, crack (t = glass thickness) (applicable only for the glass)

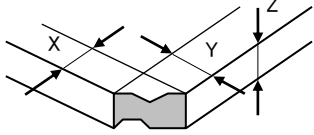
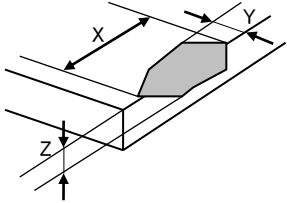
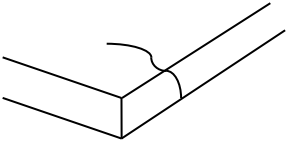
Item	Size(mm)		Acceptable Numbers
Corner		X $\leq 3$	2pcs /panel
		Y $\leq 3$	
		Z $\leq t$	
Side		X $\leq 5$	2 pcs /on one side
		Y $\leq 3$	
		Z $\leq t$	
Crack			Not acceptable